

OPERATING INSTRUCTIONS

EN

Translation of the Original

DUO 5 M | DUO 5 MC

Rotary vane pump

PFEIFFER  **VACUUM**

Dear Customer,

Thank you for choosing a Pfeiffer Vacuum product. Your new rotary vane pump is designed to support you by its performance, its perfect operation and without interfering your individual application. The name Pfeiffer Vacuum stands for high-quality vacuum technology, a comprehensive and complete range of top-quality products and first-class service. With this expertise, we have acquired a multitude of skills contributing to an efficient and secure implementation of our product.

Knowing that our product must not interfere with your actual work, we are convinced that our product offers you the solution that supports you in the effective and trouble-free execution of your individual application.

Please read these operating instructions before putting your product into operation for the first time. If you have any questions or suggestions, please feel free to contact info@pfeiffer-vacuum.de.

Further operating instructions from Pfeiffer Vacuum can be found in the [Download Center](#) on our website.

Disclaimer of liability

These operating instructions describe all models and variants of your product. Note that your product may not be equipped with all features described in this document. Pfeiffer Vacuum constantly adapts its products to the latest state of the art without prior notice. Please take into account that online operating instructions can deviate from the printed operating instructions supplied with your product.

Furthermore, Pfeiffer Vacuum assumes no responsibility or liability for damage resulting from the use of the product that contradicts its proper use or is explicitly defined as foreseeable misuse.

Copyright

This document is the intellectual property of Pfeiffer Vacuum and all contents of this document are protected by copyright. They may not be copied, altered, reproduced or published without the prior written permission of Pfeiffer Vacuum.

We reserve the right to make changes to the technical data and information in this document.

Table of contents

1	About this manual	7
1.1	Validity	7
	1.1.1 Applicable documents	7
	1.1.2 Variants	7
1.2	Target group	7
1.3	Conventions	7
	1.3.1 Instructions in the text	7
	1.3.2 Pictographs	7
	1.3.3 Stickers on product	8
	1.3.4 Abbreviations	9
2	Safety	10
2.1	General safety information	10
2.2	Safety instructions	10
2.3	Safety precautions	14
2.4	Safety precautions for vacuum pumps with magnetic coupling	14
2.5	Limits of use of product	14
2.6	Proper use	15
2.7	Foreseeable improper use	15
2.8	Personnel qualification	15
	2.8.1 Ensuring personnel qualification	16
	2.8.2 Personnel qualification for maintenance and repair	16
	2.8.3 Advanced training with Pfeiffer Vacuum	16
3	Product description	17
3.1	Function	17
	3.1.1 Gas ballast	17
	3.1.2 Vacuum safety valve	17
	3.1.3 Operating fluid, oil	17
3.2	Operating principle	18
3.3	Product features	18
3.4	Identifying product	18
3.5	Scope of delivery	18
4	Transportation and Storage	19
4.1	Transporting the vacuum pump	19
4.2	Storing vacuum pump	19
5	Installation	21
5.1	Setting up vacuum pump	21
5.2	Connect the vacuum side	21
5.3	Connecting exhaust side	22
5.4	Connect to mains power supply	23
	5.4.1 Connecting single-phase motors	24
	5.4.2 Connecting three-phase motor with 6-pin terminal board	25
	5.4.3 Setting motor protection switch	26
	5.4.4 Connecting the PTC thermistor tripping unit	26
	5.4.5 Checking direction of rotation	27
	5.4.6 Frequency converter for vacuum pumps with three-phase motor	27
5.5	Filling up operating fluid	28
6	Operation	30
6.1	Commissioning vacuum pump	30
6.2	Switching on vacuum pump	30
6.3	Operating rotary vane pump with gas ballast	31
	6.3.1 Gas ballast valve – standard version	32
	6.3.2 Gas ballast valve with inert gas connection	32

6.4	Refilling operating fluid	33
6.5	Switching off vacuum pump	34
7	Maintenance	35
7.1	Maintenance instructions	35
7.2	Maintenance instructions for magnetic coupling	36
7.3	Checklist for inspection and maintenance	36
7.4	Change the operating fluid	37
	7.4.1 Determining the degree of aging of P3 operating fluid	38
	7.4.2 Changing operating fluid	38
	7.4.3 Rinsing and cleaning rotary vane pump	40
7.5	Removing and cleaning the gas ballast valve	42
	7.5.1 Removing the gas ballast valve	42
	7.5.2 Disassembling and cleaning gas ballast valve	42
	7.5.3 Remove and clean silencer nozzle	43
	7.5.4 Install gas ballast valve	43
7.6	Changing the operating fluid type	44
8	Decommissioning	45
8.1	Shutting down for longer periods	45
8.2	Recommissioning	45
9	Recycling and disposal	46
9.1	General disposal information	46
9.2	Dispose of rotary vane pump	46
10	Malfunctions	47
11	Service solutions by Pfeiffer Vacuum	49
12	Spare parts	51
12.1	Spare part packages	51
12.2	Maintenance kit 1 – maintenance level 1	51
12.3	Overhaul kit – Maintenance level 3	52
12.4	Coupling set for versions with magnetic coupling	52
12.5	Set of vanes	52
13	Accessories	53
13.1	Accessory information	53
13.2	Order accessories	53
14	Technical data and dimensions	55
14.1	General	55
14.2	Substances in contact with the media	55
14.3	Technical data	56
14.4	Dimensions	58
	EC Declaration of Conformity	60
	UK Declaration of Conformity	61

List of tables

Tbl. 1:	Stickers on product	8
Tbl. 2:	Abbreviations used in this document	9
Tbl. 3:	Limits of use of product	15
Tbl. 4:	Features of the rotary vane pumps	18
Tbl. 5:	Recommended fuse ratings for on-site fuse protection	25
Tbl. 6:	Motor protection switch settings	26
Tbl. 7:	Maintenance intervals	37
Tbl. 8:	Troubleshooting for rotary vane pumps	48
Tbl. 9:	Spare part packages	51
Tbl. 10:	Content of maintenance kit 1	52
Tbl. 11:	Accessories for Duo 5 M	54
Tbl. 12:	Accessories for Duo 5 MC	54
Tbl. 13:	Consumables	54
Tbl. 14:	Conversion table: Pressure units	55
Tbl. 15:	Conversion table: Units for gas throughput	55
Tbl. 16:	Materials that make contact with the process media	56
Tbl. 17:	Technical data Duo 5 M	57
Tbl. 18:	Technical data Duo 5 MC	58

List of figures

Fig. 1:	Position of the stickers on the product	9
Fig. 2:	Structure of the rotary vane pump	17
Fig. 3:	Rotary vane vacuum pump functional principle	18
Fig. 4:	Transporting the vacuum pump	19
Fig. 5:	Minimum distances and permissible inclination	21
Fig. 6:	Vacuum connection with flange connection	22
Fig. 7:	Exhaust connection with flange connection	23
Fig. 8:	Motor circuit diagram, single-phase motor with switch	24
Fig. 9:	Delta connection for low voltage	25
Fig. 10:	Star circuit for high voltage	25
Fig. 11:	Connection example with PTC thermistor tripping unit	27
Fig. 12:	Filling up operating fluid	28
Fig. 13:	Gas ballast valve, standard version	32
Fig. 14:	Gas ballast valve with inert gas connection	33
Fig. 15:	Refilling operating fluid	34
Fig. 16:	Draining operating fluid	39
Fig. 17:	Removing/fitting the cap on the rotary vane pump	41
Fig. 18:	Removing the gas ballast valve	42
Fig. 19:	Individual parts of the gas ballast valve	42
Fig. 20:	Remove silencer nozzle	43
Fig. 21:	Content of maintenance kit 1 – maintenance level 1	51
Fig. 22:	Dimension diagram Duo 5 M single-phase motor (115 V)	58
Fig. 23:	Dimension diagram Duo 5 M single-phase motor (230 V)	58
Fig. 24:	Dimension diagram Duo 5 M single-phase motor (230 V, hose connection)	59
Fig. 25:	Dimension diagram Duo 5 M three-phase motor	59

1 About this manual



IMPORTANT

Read carefully before use.
Keep the manual for future consultation.

1.1 Validity

These operating instructions are a customer document of Pfeiffer Vacuum. The operating instructions describe the functions of the named product and provide the most important information for the safe use of the device. The description is written in accordance with the valid directives. The information in these operating instructions refers to the product's current development status. The document shall remain valid provided that the customer does not make any changes to the product.

1.1.1 Applicable documents

Designation	Document
Declaration of conformity	A component of these operating instructions

1.1.2 Variants

These instructions apply to DuoLine vacuum pumps.

- Duo 5 M
- Duo 5 MC

1.2 Target group

These operating instructions are aimed at all persons performing the following activities on the product:

- Transportation
- Setup (Installation)
- Usage and operation
- Decommissioning
- Maintenance and cleaning
- Storage or disposal

The work described in this document is only permitted to be performed by persons with the appropriate technical qualifications (expert personnel) or who have received the relevant training from Pfeiffer Vacuum.

1.3 Conventions

1.3.1 Instructions in the text

Usage instructions in the document follow a general structure that is complete in itself. The required action is indicated by an individual step or multi-part action steps.

Individual action step

A horizontal, solid triangle indicates the only step in an action.

- ▶ This is an individual action step.

Sequence of multi-part action steps

The numerical list indicates an action with multiple necessary steps.

1. Step 1
2. Step 2
3. ...

1.3.2 Pictographs

Pictographs used in the document indicate useful information.



Note



Tip

1.3.3 Stickers on product

This section describes all the stickers on the product along with their meanings.

	<p>Rating plate (example) The rating plate is located on the front right side next to the sight glass Motor rating plate (not shown)</p>
	<p>Sticker (red) Fill rotary vane pump with operating fluid before commissioning</p>
	<p>Sticker (yellow) – three-phase motor only Attention! Check the direction of rotation of the rotary vane pump before filling with operating fluid.</p>
	<p>Sticker (orange) – special operating fluid only Attention! Fill rotary vane pump with F4 only</p>
	<p>Sticker (blue) – special operating fluid only Attention! Fill rotary vane pump with D2 only</p>
	<p>Sense of rotation arrow (three phase motor only) The direction of rotation arrow indicates the required motor sense of rotation.</p>
	<p>Warning hot surface This sticker warns of injuries caused by high temperatures as a result of contact without protection during operation.</p>

Tbl. 1: Stickers on product

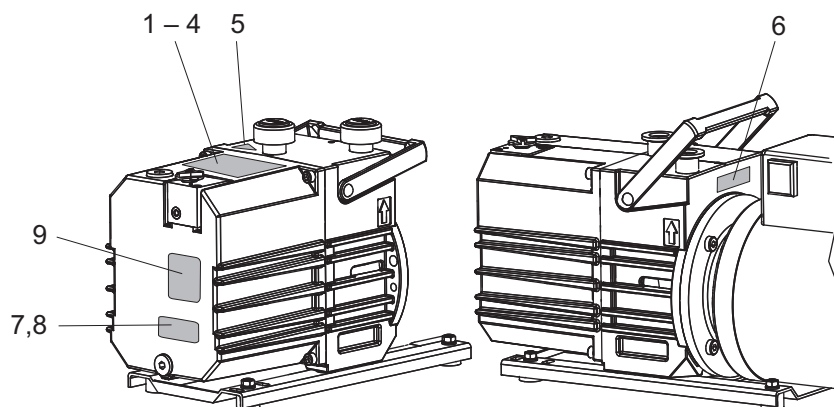

Fig. 1: Position of the stickers on the product

- | | | | |
|---|----------------------------------|---|-------------------------------------|
| 1 | Fill oil note | 6 | Sense of rotation sticker |
| 2 | Check direction of rotation note | 7 | Optionally: Note F4 Operating fluid |
| 3 | Note F4 Operating fluid | 8 | Optionally: Note D2 Operating fluid |
| 4 | Note D2 Operating fluid | 9 | Rating plate |
| 5 | Warning hot surface | | |

1.3.4 Abbreviations

Abbreviation	Explanation
BA	Operating instructions
C version	Corrosive gas version
DN	Nominal diameter (diamètre nominal)
FKM	Fluorinated rubber
I_N	Rated current
I_{max}	Maximum current
ISO	Flange: Connection in accordance with ISO 1609 and ISO 2861
M version	Version with magnetic coupling
MC version	Corrosive gas version with magnetic coupling
ODK	Operating fluid return line (oil drain kit)
OME	Oil mist filter (oil mist eliminator)
PE	Protective earth (earthed conductor)
PTC	Temperature-dependent resistor (positive temperature coefficient)
RSSR	Radial shaft seal ring
WAF	Width Across Flats
MM	Maintenance manual

Tbl. 2: Abbreviations used in this document

2 Safety

2.1 General safety information

The following 4 risk levels and 1 information level are taken into account in this document.

⚠ DANGER
<p>Immediately pending danger Indicates an immediately pending danger that will result in death or serious injury if not observed.</p> <ul style="list-style-type: none"> ▶ Instructions to avoid the danger situation

⚠ WARNING
<p>Potential pending danger Indicates a pending danger that could result in death or serious injury if not observed.</p> <ul style="list-style-type: none"> ▶ Instructions to avoid the danger situation

⚠ CAUTION
<p>Potential pending danger Indicates a pending danger that could result in minor injuries if not observed.</p> <ul style="list-style-type: none"> ▶ Instructions to avoid the danger situation

NOTICE
<p>Danger of damage to property Is used to highlight actions that are not associated with personal injury.</p> <ul style="list-style-type: none"> ▶ Instructions to avoid damage to property

i	Notes, tips or examples indicate important information about the product or about this document.
----------	--

2.2 Safety instructions

All safety instructions in this document are based on the results of the risk assessment carried out in accordance with Machinery Directive 2006/42/EC Annex I and EN ISO 12100 Section 5. Where applicable, all life cycle phases of the product were taken into account.

Risks during transport

⚠ WARNING
<p>Danger of serious injury due to falling objects Due to falling objects there is a risk of injuries to limbs through to broken bones.</p> <ul style="list-style-type: none"> ▶ Take particular care and pay special attention when transporting products manually. ▶ Do not stack the products. ▶ Wear protective equipment, e.g. safety shoes.

Risks during installation

⚠ DANGER**Danger to life from electric shock**

Touching exposed and voltage-bearing elements causes an electric shock. Improper connection of the mains supply leads to the risk of touchable live housing parts. There is a risk to life.

- ▶ Before the installation, check that the connection leads are voltage-free.
- ▶ Make sure that electrical installations are only carried out by qualified electricians.
- ▶ Provide adequate grounding for the device.
- ▶ After connection work, carry out an earthed conductor check.

⚠ WARNING**Danger of poisoning from toxic vapors**

Igniting and heating synthetic operating fluid generates toxic vapors. Danger of poisoning if inhaled.

- ▶ Observe the application instructions and precautions.
- ▶ Do not allow tobacco products to come into contact with the operating fluid.

⚠ CAUTION**Danger of burns on hot surfaces**

Depending on the operating and ambient conditions, the surface temperature of the vacuum pump can increase to above 70 °C. If access to the vacuum pump is unrestricted, there is a danger of burns due to contact with hot surfaces.

- ▶ Install suitable touch protection if the vacuum pump is accessible to untrained persons.
- ▶ Allow the vacuum pump to cool down before carrying out any work.
- ▶ Contact Pfeiffer Vacuum for suitable touch protection in system solutions.

Risks during operation

⚠ WARNING**Danger of poisoning due to toxic process media escaping from the exhaust pipe**

During operation with no exhaust line, the vacuum pump allows exhaust gases and vapors to escape freely into the air. There is a risk of injury and fatality due to poisoning in processes with toxic process media.

- ▶ Observe the pertinent regulations for handling toxic process media.
- ▶ Safely purge toxic process media via an exhaust line.
- ▶ Use appropriate filter equipment to separate toxic process media.

⚠ WARNING**Danger of poisoning from toxic vapors**

Igniting and heating synthetic operating fluid generates toxic vapors. Danger of poisoning if inhaled.

- ▶ Observe the application instructions and precautions.
- ▶ Do not allow tobacco products to come into contact with the operating fluid.

⚠ CAUTION**Risk of injury from entrapment of body parts**

After a power failure or a standstill as a result of overheating, the motor restarts automatically. A risk exists of minor injury to fingers and hands (e.g., hematoma), from direct contact with the vacuum flange.

- ▶ Maintain sufficient distance to the vacuum flange during all work.
- ▶ Safely disconnect motor from the mains.
- ▶ Secure the motor against re-start.

⚠ CAUTION

Danger of injury from bursting as a result of high pressure in the exhaust line

Faulty or inadequate exhaust pipes lead to dangerous situations, e.g. increased exhaust pressure. There is a danger of bursting. Injuries caused by flying fragments, the escaping of high pressure, and damage to the unit cannot be excluded.

- ▶ Route the exhaust line without shut-off units.
- ▶ Observe the permissible pressures and pressure differentials for the product.
- ▶ Check the function of the exhaust line on a regular basis.

⚠ CAUTION

Danger of burns on hot surfaces

Depending on the operating and ambient conditions, the surface temperature of the vacuum pump can increase to above 70 °C. If access to the vacuum pump is unrestricted, there is a danger of burns due to contact with hot surfaces.

- ▶ Install suitable touch protection if the vacuum pump is accessible to untrained persons.
- ▶ Allow the vacuum pump to cool down before carrying out any work.
- ▶ Contact Pfeiffer Vacuum for suitable touch protection in system solutions.

Risks during maintenance, decommissioning and malfunctions

⚠ WARNING

Health hazard through poisoning from toxic contaminated components or devices

Toxic process media result in contamination of devices or parts of them. During maintenance work, there is a risk to health from contact with these poisonous substances. Illegal disposal of toxic substances causes environmental damage.

- ▶ Take suitable safety precautions and prevent health hazards or environmental pollution by toxic process media.
- ▶ Decontaminate affected parts before carrying out maintenance work.
- ▶ Wear protective equipment.

⚠ WARNING

Danger of injury from strong magnetic field

There is a risk of injury for people with pacemakers and medical implants.

- ▶ Make sure that such individuals do not enter the sphere of influence (≤ 2 m) of the magnetic field.
- ▶ Identify rooms in which magnetic couplings are openly accessible with the symbol: **"No access for people with pacemakers"**.
- ▶ Always keep disassembled couplings away from computers, data carriers, and other electronic components.

⚠ WARNING

Danger of poisoning from toxic vapors

Igniting and heating synthetic operating fluid generates toxic vapors. Danger of poisoning if inhaled.

- ▶ Observe the application instructions and precautions.
- ▶ Do not allow tobacco products to come into contact with the operating fluid.

⚠ WARNING

Health hazard and risk of environmental damage from toxic contaminated operating fluid

Toxic process media can cause operating fluid contamination. When changing the operating fluid, there is a health hazard due to contact with poisonous substances. Illegal disposal of toxic substances causes environmental damage.

- ▶ Wear suitable personal protective equipment when handling these media.
- ▶ Dispose of the operating fluid according to locally applicable regulations.

⚠ WARNING**Danger to life from electric shock in the event of a fault**

In the event of a fault, devices connected to the mains may be live. There is a danger to life from electric shock when making contact with live components.

- ▶ Always keep the mains connection freely accessible so you can disconnect it at any time.

⚠ CAUTION**Scalding from hot operating fluid**

Danger of burns when draining operating fluid if it comes into contact with the skin.

- ▶ Wear protective equipment.
- ▶ Use a suitable collection receptacle.

⚠ CAUTION**Risk of injury from entrapment of body parts**

After a power failure or a standstill as a result of overheating, the motor restarts automatically. A risk exists of minor injury to fingers and hands (e.g., hematoma), from direct contact with the vacuum flange.

- ▶ Maintain sufficient distance to the vacuum flange during all work.
- ▶ Safely disconnect motor from the mains.
- ▶ Secure the motor against re-start.

⚠ CAUTION**Danger of burns on hot surfaces**

In the event of a fault, the surface temperature of the vacuum pump can increase to above 105 °C.

- ▶ Allow the vacuum pump to cool down before carrying out any work.
- ▶ Wear personal protective equipment if necessary.

⚠ CAUTION**Danger of injury from moving parts**

After a power failure or a standstill as a result of overheating, the motor restarts automatically. There is a risk of injury to fingers and hands if they enter the operating range of rotating parts.

- ▶ Safely disconnect motor from the mains.
- ▶ Secure the motor against reactivation.
- ▶ Dismantle the vacuum pump for inspection, away from the system if necessary.

Risks during disposal**⚠ WARNING****Health hazard through poisoning from toxic contaminated components or devices**

Toxic process media result in contamination of devices or parts of them. During maintenance work, there is a risk to health from contact with these poisonous substances. Illegal disposal of toxic substances causes environmental damage.

- ▶ Take suitable safety precautions and prevent health hazards or environmental pollution by toxic process media.
- ▶ Decontaminate affected parts before carrying out maintenance work.
- ▶ Wear protective equipment.

2.3 Safety precautions



Duty to provide information on potential dangers

The product holder or user is obliged to make all operating personnel aware of dangers posed by this product.

Every person who is involved in the installation, operation or maintenance of the product must read, understand and adhere to the safety-related parts of this document.



Infringement of conformity due to modifications to the product

The Declaration of Conformity from the manufacturer is no longer valid if the operator changes the original product or installs additional equipment.

- Following the installation into a system, the operator is required to check and re-evaluate the conformity of the overall system in the context of the relevant European Directives, before commissioning that system.

General safety precautions when handling the product

- ▶ Observe all applicable safety and accident prevention regulations.
- ▶ Check that all safety measures are observed at regular intervals.
- ▶ Do not expose body parts to the vacuum.
- ▶ Always ensure a secure connection to the earthed conductor (PE).
- ▶ Never disconnect plug connections during operation.
- ▶ Observe the above shutdown procedures.
- ▶ Keep lines and cables away from hot surfaces (> 70 °C).
- ▶ Never fill or operate the unit with cleaning agents or cleaning agent residues.
- ▶ Do not carry out your own conversions or modifications on the unit.
- ▶ Observe the unit protection class prior to installation or operation in other environments.
- ▶ Provide suitable touch protection, if the surface temperature exceeds 70 °C.

2.4 Safety precautions for vacuum pumps with magnetic coupling

The following safety instructions are only valid for the working with a drive system of a vacuum pump with a magnetic coupling:

Safety precautions

- ▶ Keep a magnetic coupling away from people with pacemakers.
 - Minimum distance: **2 m**
- ▶ Avoid convergence of magnetic coupling components.
- ▶ Keep magnetized parts away from the magnetic coupling.
- ▶ Always keep a disassembled magnetic coupling away from computers, data carriers and other electronic components.
 - The magnetic coupling can influence operational reliability of electrical and electronic devices.

2.5 Limits of use of product

Installation location	<ul style="list-style-type: none"> • Indoors, protected from dust deposits • Outdoors, protected from direct weather influences
Installation altitude	max. 1000 m above sea level ¹⁾
Protection class (according to IEC 61010)	I
Degree of pollution (according to IEC 61010)	2
Overvoltage category	II
Protection class	IP54
permissible angle of inclination	± 1 °
Ambient temperature	+12 °C to +40 °C

1) When installing at altitudes > 1000 m above sea level, reduce the power of the motor or limit the ambient temperature, as the vacuum pump will heat up more.

Relative air humidity	max. 85%
Pumped medium intake temperature, max.	+40 °C
Exhaust pressure of the vacuum pump	≤ 1500 hPa absolute
Exhaust pressure at OME	max. atmospheric pressure

Tbl. 3: Limits of use of product

2.6 Proper use

- ▶ Use the vacuum pump for vacuum generation only.
- ▶ When pumping media with an oxygen concentration level of $\geq 21\%$, only use perfluorinated, synthetic oils (F4, F5, A113) as operating fluid.
- ▶ Adhere to the installation, commissioning, operating, and maintenance instructions.
- ▶ Do not use any accessory parts other than those recommended by Pfeiffer Vacuum.

2.7 Foreseeable improper use

Improper use of the product invalidates all warranty and liability claims. Any use that is counter to the purpose of the product, whether intentional or unintentional, is regarded as improper use; in particular:

- Pumping of corrosive media (exception: C version of the rotary vane pumps)
- Pumping radioactive media
- Pumping of gases that introduce an ignition source to the suction chamber
- Pumping of gases that contain contamination such as particles, dust, or condensate
- Pumping explosive media
- Pumping of media with a propensity to sublimation
- Pumping of fluids
- Using the vacuum pump in potentially explosive atmospheres
- Using the vacuum pump outside the specified area of application
- Using for pressure generation
- Use in strong electrical, magnetic, or electromagnetic fields
- Connecting to vacuum pumps and units that are not designed for this purpose according to their operating instructions
- Connecting to units with exposed live parts
- Use of accessories or spare parts not listed in these instructions
- Use of operating fluids other than those specified by Pfeiffer Vacuum
- Use of D2 or mineral oil as operating fluid with an oxygen concentration level of $> 21\%$

Mineral oils are combustible and ignite at high temperatures and when they come into contact with pure oxygen. These oils oxidize heavily and thus lose their lubricating capacity.

2.8 Personnel qualification

The work described in this document may only be carried out by persons who have appropriate professional qualifications and the necessary experience or who have completed the necessary training as provided by Pfeiffer Vacuum.

Training people

1. Train the technical personnel on the product.
2. Only let personnel to be trained work with and on the product when under the supervision of trained personnel.
3. Only allow trained technical personnel to work with the product.
4. Before starting work, make sure that the commissioned personnel have read and understood these operating instructions and all applicable documents, in particular the safety, maintenance and repair information.

2.8.1 Ensuring personnel qualification

Specialist for mechanical work

Only a trained specialist may carry out mechanical work. Within the meaning of this document, specialists are people responsible for construction, mechanical installation, troubleshooting and maintenance of the product, and who have the following qualifications:

- Qualification in the mechanical field in accordance with nationally applicable regulations
- Knowledge of this documentation

Specialist for electrotechnical work

Only a trained electrician may carry out electrical engineering work. Within the meaning of this document, electricians are people responsible for electrical installation, commissioning, troubleshooting, and maintenance of the product, and who have the following qualifications:

- Qualification in the electrical engineering field in accordance with nationally applicable regulations
- Knowledge of this documentation

In addition, these individuals must be familiar with applicable safety regulations and laws, as well as the other standards, guidelines, and laws referred to in this documentation. The above individuals must have an explicitly granted operational authorization to commission, program, configure, mark, and earth devices, systems, and circuits in accordance with safety technology standards.

Trained individuals

Only adequately trained individuals may carry out all works in other transport, storage, operation and disposal fields. Such training must ensure that individuals are capable of carrying out the required activities and work steps safely and properly.

2.8.2 Personnel qualification for maintenance and repair



Advanced training courses

Pfeiffer Vacuum offers advanced training courses to maintenance levels 2 and 3.

Adequately trained individuals are:

- **Maintenance level 1**
 - Customer (trained specialist)
- **Maintenance level 2**
 - Customer with technical education
 - Pfeiffer Vacuum service technician
- **Maintenance level 3**
 - Customer with Pfeiffer Vacuum service training
 - Pfeiffer Vacuum service technician

2.8.3 Advanced training with Pfeiffer Vacuum

For optimal and trouble-free use of this product, Pfeiffer Vacuum offers a comprehensive range of courses and technical trainings.

For more information, please contact [Pfeiffer Vacuum technical training](#).

3 Product description

3.1 Function

DuoLine rotary vane vacuum pumps are two-stage, oil-sealed rotary positive displacement pumps for use in coarse and medium vacuum. The rotary vane pump has a contactless and wear proof drive with magnetic coupling. The pump housing is hermetically sealed.

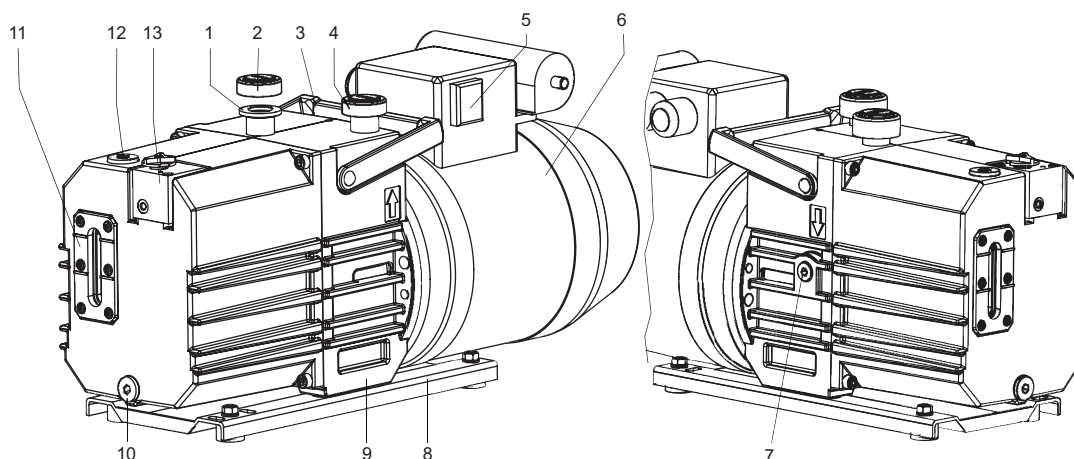

Fig. 2: Structure of the rotary vane pump

- | | |
|--|----------------------|
| 1 Vacuum connection | 8 Base plate |
| 2 Protective cap | 9 Stand |
| 3 Handle | 10 Drain screw |
| 4 Exhaust connection | 11 Sight glass |
| 5 Mains switch (single-phase motor only) | 12 Filler screw |
| 6 Motor | 13 Gas ballast valve |
| 7 Locking screw (oil pressure switch) | |

3.1.1 Gas ballast

The gas ballast unit is used to blend ambient air or inert gas with the process gas in the pumping system. Increasing the air content compresses and expels a pumped gas/vapor mixture within specific limits, without causing condensation in the suction chamber.

3.1.2 Vacuum safety valve

The rotary vane pumps are equipped with a vacuum safety valve. This separates the rotary vane pump from the vacuum chamber in the event of intentional or unintentional standstill, and vents the pumping system with the displaced gas so that oil does not rise into the vacuum chamber. After switching on, the valve opens after a delay.

3.1.3 Operating fluid, oil

The rotary vane pump circulates the operating fluid to separate condensate, contaminants and dust particles from the operating fluid and deposit them in the sump of the storage tank. This means that the rotary vane pumps have a very large operating fluid reservoir.

The pump oil, also known as operating fluid, fulfills various tasks in a rotary vane pump:

- lubrication of all moving parts
- filling part of the dead volume under the exhaust valve
- sealing the gap between the intake and exhaust channel, and between the vanes and the working chamber
- ensuring an optimal temperature balance through heat transfer

3.2 Operating principle

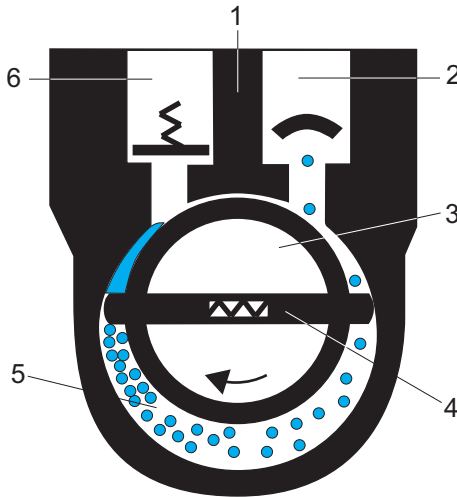

Fig. 3: Rotary vane vacuum pump functional principle

- | | |
|-------------------------|--------------------|
| 1 Housing | 4 Vane |
| 2 Vacuum flange (inlet) | 5 Suction chamber |
| 3 Rotor | 6 Exhaust (outlet) |

The rotary vane pump is an oil-sealed rotary displacement pump. The pumping system comprises the housing, the eccentrically mounted rotor, and the centrifugal and spring-loaded radially sliding vanes, which divide the suction chamber into multiple chambers. The volume of each chamber changes periodically as the rotor rotates. This causes the gas to be drawn in at the vacuum flange, and compressed in the suction chamber by the rotation of the rotor until the exhaust valve opens against the atmospheric pressure at the outlet and expels the gas. The exhaust valve is oil-sealed. When the valve opens, a small quantity of oil penetrates into the suction chamber. In addition to lubrication, this also causes the gaps between the rotor, stator, and vanes to seal.

3.3 Product features

Pump type	Characteristics
Duo 5 M	Standard version with magnetic coupling
Duo 5 MC	MC version; differs compared to the standard version by: <ul style="list-style-type: none"> • Operating fluid F4 • Magnetic coupling encapsulated on the pump side • Vane material changed • Hose connection on the gas ballast valve • Leakage rate $\leq 1 \times 10^{-6}$ Pa m³/s

Tbl. 4: Features of the rotary vane pumps

3.4 Identifying product

- ▶ To ensure clear identification of the product when communicating with Pfeiffer Vacuum, always keep all of the information on the rating plate to hand.
- ▶ Observe the motor-specific data on the motor rating plate attached separately.
- ▶ Learn about certifications through test seals on the product or at www.certipedia.com.

3.5 Scope of delivery

- Rotary vane vacuum pump with motor
- Operating fluid (other than F4, F5 and A113)
- Centering ring with cone sieve and O-ring for the connection flange
- Locking caps for both connection flanges
- Operating instructions

4 Transportation and Storage

4.1 Transporting the vacuum pump

⚠ WARNING

Danger of serious injury due to falling objects

Due to falling objects there is a risk of injuries to limbs through to broken bones.

- ▶ Take particular care and pay special attention when transporting products manually.
- ▶ Do not stack the products.
- ▶ Wear protective equipment, e.g. safety shoes.



Preparations for transport

Pfeiffer Vacuum recommends keeping the transport packaging and original protective cover.

Safe transport of the product

1. Observe the weight specified on the packaging.
2. Use a transport aid if necessary (trolley, lift truck).
3. Transport the product in its original packaging.
4. Always place the product on an adequately sized, level surface.

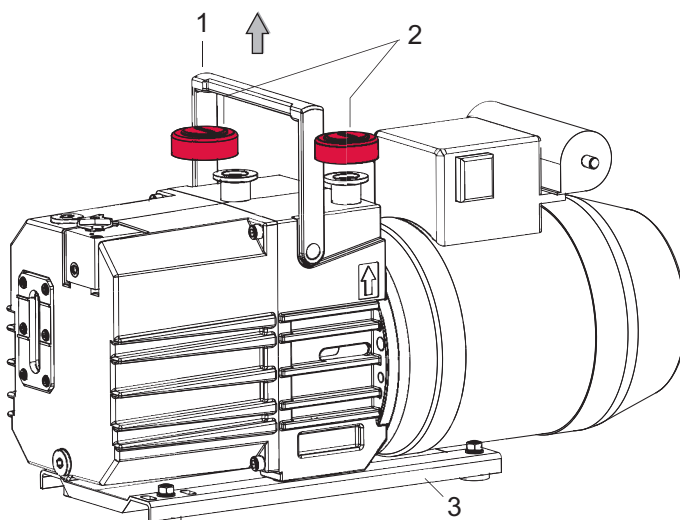

Fig. 4: Transporting the vacuum pump

- | | |
|-------------------|--------------|
| 1 Handle | 3 Base plate |
| 2 Protective caps | |

Transporting the vacuum pump without its packaging

1. Unpack the vacuum pump.
2. To protect the inside of the pump, leave both protective caps on the connection flanges during transport.
3. For lifting, use the handle provided for this purpose, located on the top of the pump.
4. Lift the vacuum pump out of the transport packaging.
5. Always place the vacuum pump on an adequately sized, level surface.

4.2 Storing vacuum pump



Storage

Pfeiffer Vacuum recommends storing the products in their original transport packaging.

Safe storing vacuum pump

1. Fill the vacuum pump with operating fluid up to the upper edge of the sight glass.
2. Close both connection flanges and all openings on the vacuum pump.
3. Make sure that the gas ballast valve is closed.
4. Store the vacuum pump only in dry, dust-free rooms, within the specified ambient conditions.
5. In rooms with humid or aggressive atmospheres: Hermetically seal the vacuum pump together with a drying agent in a plastic bag.
6. Change the operating fluid if the storage period is longer than 2 years.

5 Installation

5.1 Setting up vacuum pump

⚠ CAUTION

Danger of burns on hot surfaces

Depending on the operating and ambient conditions, the surface temperature of the vacuum pump can increase to above 70 °C. If access to the vacuum pump is unrestricted, there is a danger of burns due to contact with hot surfaces.

- ▶ Install suitable touch protection if the vacuum pump is accessible to untrained persons.
- ▶ Allow the vacuum pump to cool down before carrying out any work.
- ▶ Contact Pfeiffer Vacuum for suitable touch protection in system solutions.

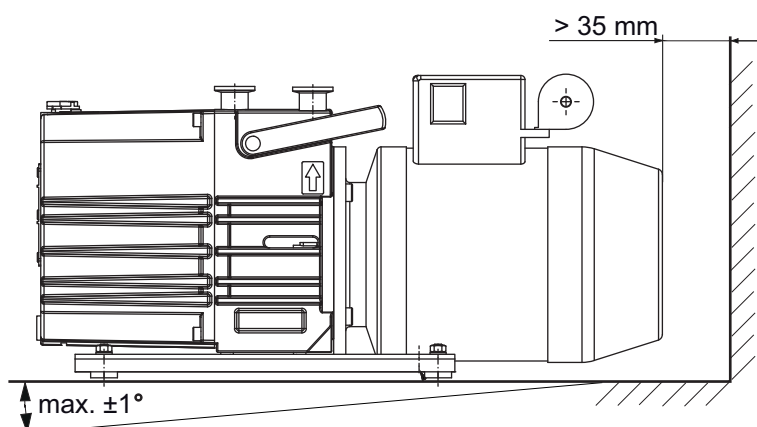

Fig. 5: Minimum distances and permissible inclination

Procedure

- When selecting the installation location, observe the requirement for touch protection to prevent burns.
 - Closed housing: no touch protection required
 - Access for trained individuals only: no touch protection required
 - Unrestricted access for untrained individuals: Touch protection required
- Pfeiffer Vacuum supports you in implementing the touch protection.
 1. Place the vacuum pump on a flat, horizontal surface, to safeguard the operating fluid supply.
 2. Screw the base plate of the vacuum pump to the mounting surface if necessary.
 3. Observe the max. permissible angles of inclination.
 4. When installing the pump in a closed housing, ensure adequate air circulation.
 5. Keep the sight glass and gas ballast valve visible and freely accessible.
 6. Keep the voltage and frequency specifications on the motor rating plate visible and freely accessible.
 7. Fill with operating fluid prior to first commissioning.
 - Quantity and type of the operating fluid can be found on the rating plate.

5.2 Connect the vacuum side

NOTICE

Property damage from contaminated gases

Pumping gases that contain contamination damages the vacuum pump.

- ▶ Use suitable filters or separators from the Pfeiffer Vacuum range of accessories, to protect the vacuum pump.

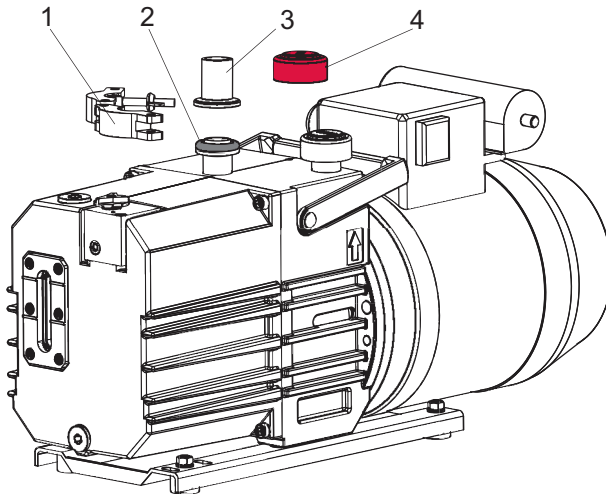

Fig. 6: Vacuum connection with flange connection

- | | |
|--|------------------|
| 1 Circlip | 3 Vacuum line |
| 2 Centering ring with cone strainer and o-ring | 4 Protective cap |

Procedure

1. Remove the protective cap from the vacuum flange.
2. Make sure that the cone sieve and centering ring are in the vacuum flange.
3. Establish the shortest possible connection between vacuum pump and vacuum chamber.
4. Choose a minimum vacuum line cross section equal to the nominal diameter of the connection flange.
5. Depending on the pump type, use PVC or metallic hoses with flange connections from the [Pfeiffer Vacuum component shop](#).
6. Support or suspend the piping to the vacuum pump so that no piping system forces act on the vacuum pump.
7. Connect both flanges with a circlip.
8. Use a separator or filter from the Pfeiffer Vacuum line of [accessories](#) if necessary.

5.3 Connecting exhaust side

CAUTION

Danger of injury from bursting as a result of high pressure in the exhaust line

Faulty or inadequate exhaust pipes lead to dangerous situations, e.g., increased exhaust pressure. There is a danger of bursting. Injuries caused by flying fragments, the escaping of high pressure, and damage to the unit cannot be excluded.

- ▶ Route the exhaust line without shut-off units.
- ▶ Observe the maximum permissible pressure of 1,500 hPa (absolute).
- ▶ Observe the permissible pressures and pressure differentials for the product.
- ▶ Check the function of the exhaust line on a regular basis.

NOTICE

Malfunction and damage to the vacuum pump from inadmissible exhaust line installation

Negative pressure in the exhaust line causes malfunctions and damage to the vacuum pump. Negative pressure is permitted only in rotary vane vacuum pumps with magnetic coupling.

- ▶ When dissipating gases, make sure that the exhaust pressure is at least 250 hPa higher than the intake pressure.



Installation and operation of accessories

Pfeiffer Vacuum offers a series of special, compatible accessories for its rotary vane pumps.

- You can find information and ordering options for approved [accessories](#) online.
- Described accessories are not included in the shipment.



Condensate separator

Pfeiffer Vacuum recommends installing a condensate separator, with condensate drain at the lowest point of the exhaust line.

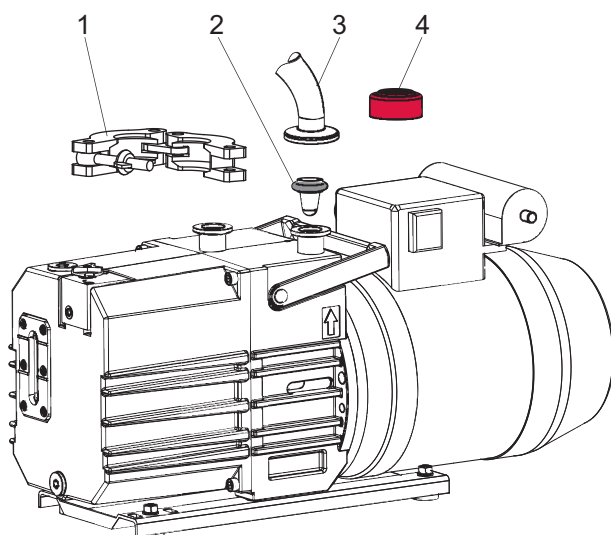

Fig. 7: Exhaust connection with flange connection

- | | |
|---|------------------|
| 1 Clamping ring | 3 Exhaust line |
| 2 Centering ring with O-ring and cone sieve | 4 Protective cap |

Procedure

1. Remove the protective cap from the exhaust flange.
2. Ensure that the centering ring with cone sieve is fitted in the exhaust flange.
3. Choose a minimum exhaust line diameter equal to the nominal diameter of the connection flange.
4. Depending on the pump type, use PVC or metallic hoses with flange connections from the [Pfeiffer Vacuum component shop](#).
5. Route the piping downwards from the vacuum pump, to prevent condensate return.
6. Support or suspend the piping to the vacuum pump so that no piping system forces act on the vacuum pump.
7. Connect both flanges with a circlip.

5.4 Connect to mains power supply

⚠ DANGER

Danger to life from electric shock

Touching exposed and voltage-bearing elements causes an electric shock. Improper connection of the mains supply leads to the risk of touchable live housing parts. There is a risk to life.

- ▶ Before the installation, check that the connection leads are voltage-free.
- ▶ Make sure that electrical installations are only carried out by qualified electricians.
- ▶ Provide adequate grounding for the device.
- ▶ After connection work, carry out an earthed conductor check.

⚠ CAUTION

Danger of injury from moving parts

After a power failure or a standstill as a result of overheating, the motor restarts automatically. There is a risk of injury to fingers and hands if they enter the operating range of rotating parts.

- ▶ Safely disconnect motor from the mains.
- ▶ Secure the motor against reactivation.
- ▶ Dismantle the vacuum pump for inspection, away from the system if necessary.

NOTICE

Risk of property damage from excess voltage

Incorrect or excessive mains voltage will destroy the motor.

- ▶ Always observe the motor rating plate specifications.
- ▶ Route the mains connection in accordance with locally applicable provisions.
- ▶ Always provide a suitable mains fuse to protect the motor and supply cable in the event of a fault.

Depending on the pump type, different motor designs or mains voltages can be used:

- Single-phase motor for fixed voltage with
 - inbuilt thermal protection switch,
 - mains switch and
 - Connecting cable
- Three phase motor (without switch and mains cable)

5.4.1 Connecting single-phase motors

i **The magnetic coupling does not offer an overload protection.**
 The magnetic coupling's torque is so strong that it does not provide any overload protection for the motor.

Vacuum pumps with single-phase motors are equipped with an installed thermal protection switch. In event of excess temperature, the protection switch interrupts the motor current, but does not offer a permanent shut-down of the motor. Once the engine has cooled, the vacuum pump restarts automatically.

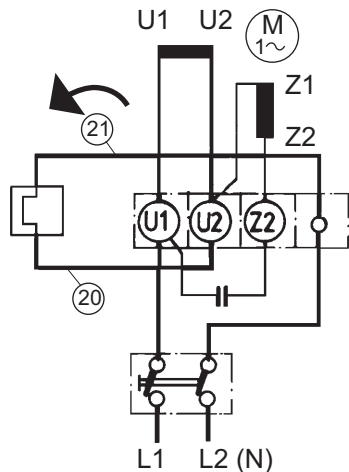

Fig. 8: Motor circuit diagram, single-phase motor with switch

Motor voltage [V], ±5 %	Mains frequency [Hz]	Rated (nominal) current [A]	Recommended fuse, slow-blow [A]
95 – 120	50	5.5	16
105 – 120	60	5.9	16
200 – 240	50	2.75	6
208 – 240	60	2.95	6
220 – 240	50	3.1	6
220 – 240	60	2.7	6

Tbl. 5: Recommended fuse ratings for on-site fuse protection

On-site fuse protection

- ▶ For the protection of the motor in case of malfunction, always provide fuse protection according to the regulations applicable for the region.

5.4.2 Connecting three-phase motor with 6-pin terminal board

NOTICE

Property damage from high starting torque

The specific load behavior of the vacuum pump requires direct on-line starting at full motor power. Engine damage occurs if a different starting circuit is used.

- ▶ Always start the motor directly.
- ▶ **Never** use a star-delta start-up circuit.

Connectors U1 – L2, V1 – L1 and W1 – L3 rotate the motor shaft clockwise when looking at the motor fan.

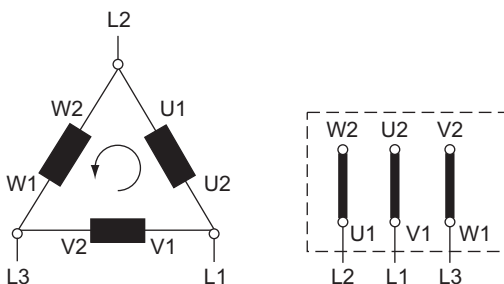

Fig. 9: Delta connection for low voltage

The 3 phases are connected in series, and their connection points connected to the mains. The voltage per phase is equal to the mains voltage, while the mains current is $\sqrt{3}$ times the phase current. The delta connection is marked with the Δ symbol. The voltage between the incoming mains supply lines is called mains voltage. The mains current is the current flowing in the incoming supply lines.

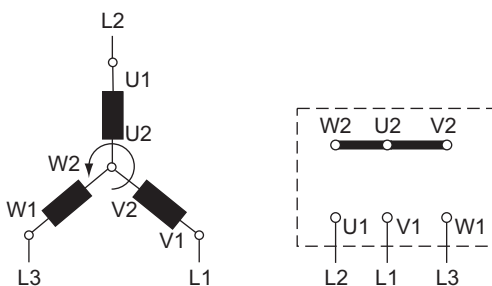

Fig. 10: Star circuit for high voltage

The ends of the 3 phases are connected in the star point. The terminal voltage is $\sqrt{3}$ times the phase voltage, the mains current is equal to the phase current. The star circuit is marked with the Y symbol.

5.4.3 Setting motor protection switch



The magnetic coupling does not offer an overload protection.

The magnetic coupling's torque is so strong that it does not provide any overload protection for the motor.

Motor protection switches are current-dependent protective devices for the drive motors. Protection switches with slow tripping characteristics are suitable. When adjusting the motor protection switch, take into consideration that certain operating conditions (for example, cold pump start) can cause short-term increases in power input.

An increase of 1.5 times the rated current over a 2 minute period is permissible for the drive motors (in accordance with EN 60034-1), without tripping the motor protection switch.

Voltage [V]	Frequency [Hz]	Motor rating [kW]	I_N [A]	I_{max} [A]
190 – 210	50	0.25	1.55	6
330 – 365	50	0.25	0.9	3
200 – 230	60	0.25	1.35	5
346 – 400	60	0.25	0.78	3
218 – 242	50	0.25	1.7	8
380 – 420	50	0.25	1.0	5
250 – 277	60	0.3	1.7	8
440 – 480	60	0.3	1.0	5

Tbl. 6: Motor protection switch settings

Procedure

- ▶ Set the appropriate value on the contactor.

5.4.4 Connecting the PTC thermistor tripping unit



Tripping units store the shut-down

Pfeiffer Vacuum recommends connecting motors with PTC in the stator winding to a PTC resistor tripping device for protection against overload.

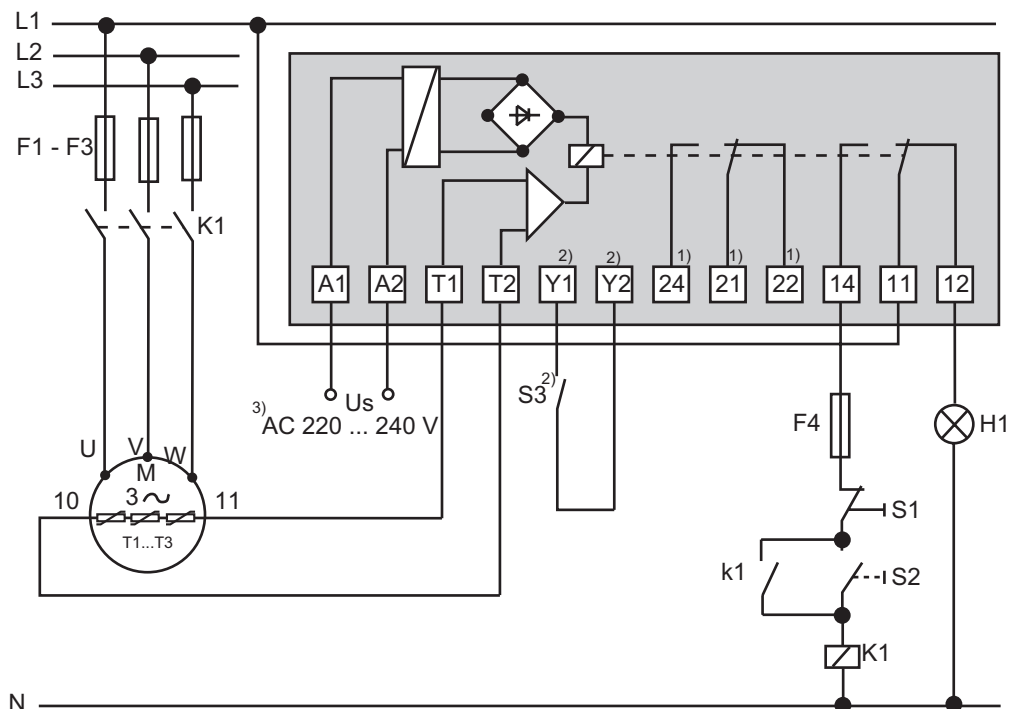

Fig. 11: Connection example with PTC thermistor tripping unit

U _s	Supply voltage	T1 – T3	PTC resistor sensor
S ₁	AUS button	H1	Tripping indicator
S ₂	EIN button	M	Motor, 3-phase
S ₃	RESET button	¹⁾	For devices with two relay outputs only
K1	Contactor	²⁾	For MSR type (model) only
F1 – F4	Fuses	³⁾	Only for order no.: P 4768 052 FQ

Procedure

- ▶ After shut-down, switch the tripping unit back on manually via the installed RESET button or via the external RESET S3.
 - Switching on mains detected as automatic RESET.

5.4.5 Checking direction of rotation



Operating fluid leaks out

The direction of rotation must be checked on vacuum pumps with three phase motors. If the direction of rotation for the vacuum pump is incorrect, there is a risk of operating fluid escaping at the vacuum flange.

- Check the direction of rotation before refilling operating fluid.

Procedure

1. Switch on the rotary vane pump briefly (2 to 3 seconds).
 - The motor and motor fan must rotate clockwise (see the arrow on the fan cover).
2. If the direction of rotation is incorrect, exchange the 2 phases on the connection cable.
3. Refill the operating fluid.

5.4.6 Frequency converter for vacuum pumps with three-phase motor

Rotary vane pumps with variable rotation speed can be operated within a mains frequency range of 35 to 60 Hz. Start-up is ramped (maximum run-up time: 30 s). Shutdown can take place immediately.

5.5 Filling up operating fluid

⚠ WARNING

Danger of poisoning from toxic vapors

Igniting and heating synthetic operating fluid generates toxic vapors. Danger of poisoning if inhaled.

- ▶ Observe the application instructions and precautions.
- ▶ Do not allow tobacco products to come into contact with the operating fluid.

NOTICE

Risk of damage due to the use of non-approved operating fluid

Product-specific performance data are not achieved. All liability and warranty claims against Pfeiffer Vacuum are also excluded.

- ▶ Only use approved operating fluids.
- ▶ Only use other application-specific operating fluids after consultation with Pfeiffer Vacuum.

Approved operating fluid

- P3 for standard applications
- F4 for corrosive gas model
- D2 for special applications (such as higher operating temperatures)

Reading operating fluid type on rating plate

- ▶ Please refer to rating plate of the vacuum pump for type and quantity of intended operating fluid.
 - Only the operating fluid used during initial installation is permissible.
 - D2 is permitted as a replacement for D1.
- ▶ Contact Pfeiffer Vacuum if you want to use another type of operating fluid.

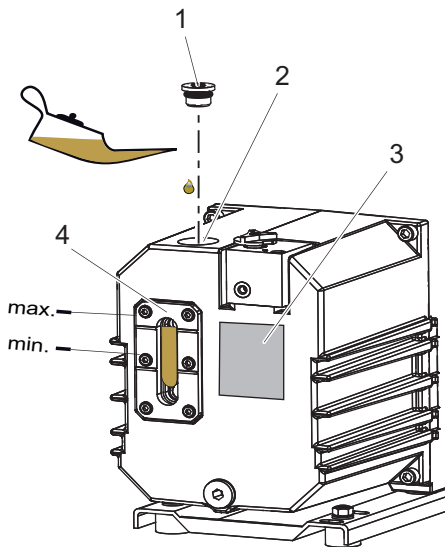

Fig. 12: Filling up operating fluid

- | | |
|----------------------------|----------------|
| 1 Filler screw with o-ring | 3 Rating plate |
| 2 Filler hole | 4 Sight glass |

Consumables

- Operating fluid of the vacuum pump

Required tools

- Allen key, **WAF 8**
- Calibrated torque wrench (tightening factor ≤ 2.5)

Filling up operating fluid

1. Unscrew the filler screw.
2. Refill the operating fluid:
 - Initial filling with cold vacuum pump: A maximum of 3/4 of the min./max. range.
3. Screw in the filler screw again.
 - Be careful with the o-ring.
 - Tightening torque: **3.0 Nm**

6 Operation

6.1 Commissioning vacuum pump

WARNING

Danger of poisoning due to toxic process media escaping from the exhaust pipe

During operation with no exhaust line, the vacuum pump allows exhaust gases and vapors to escape freely into the air. There is a risk of injury and fatality due to poisoning in processes with toxic process media.

- ▶ Observe the pertinent regulations for handling toxic process media.
- ▶ Safely purge toxic process media via an exhaust line.
- ▶ Use appropriate filter equipment to separate toxic process media.

CAUTION

Danger of injury from bursting as a result of high pressure in the exhaust line

Faulty or inadequate exhaust pipes lead to dangerous situations, e.g. increased exhaust pressure. There is a danger of bursting. Injuries caused by flying fragments, the escaping of high pressure, and damage to the unit cannot be excluded.

- ▶ Route the exhaust line without shut-off units.
- ▶ Observe the permissible pressures and pressure differentials for the product.
- ▶ Check the function of the exhaust line on a regular basis.

Procedure

- ▶ Check the operating fluid in the sight glass.
- ▶ Compare the voltage and frequency specifications on the motor rating plate with the available mains voltage and frequency.
- ▶ Protect the vacuum pump from sucking in contamination using suitable measures.
- ▶ Check the operating fluid at regular intervals.
- ▶ Check the exhaust connection for free passage (max. permissible pressure: 1,500 hPa absolute).

6.2 Switching on vacuum pump

CAUTION

Risk of injury from entrapment of body parts

After a power failure or a standstill as a result of overheating, the motor restarts automatically. A risk exists of minor injury to fingers and hands (e.g., hematoma), from direct contact with the vacuum flange.

- ▶ Maintain sufficient distance to the vacuum flange during all work.
- ▶ Safely disconnect motor from the mains.
- ▶ Secure the motor against re-start.

CAUTION

Danger of injury if hair or loose clothing is pulled in

There is a danger of injury from getting pulled in at rotating parts of the fan.

- ▶ Do not wear loose-fitting jewelry, or hide it under clothing.
- ▶ Wear close-fitting clothing.
- ▶ Use a hair net if necessary.

⚠ CAUTION**Danger of burns on hot surfaces**

Depending on the operating and ambient conditions, the surface temperature of the vacuum pump can increase to above 70 °C. If access to the vacuum pump is unrestricted, there is a danger of burns due to contact with hot surfaces.

- ▶ Install suitable touch protection if the vacuum pump is accessible to untrained persons.
- ▶ Allow the vacuum pump to cool down before carrying out any work.
- ▶ Contact Pfeiffer Vacuum for suitable touch protection in system solutions.

NOTICE**Risk of damage to the drive from increased motor current consumption**

At an intake pressure of approximately 300 hPa and under unfavorable operating conditions (such as for example exhaust side counterpressure), the power input exceeds the rated current.

- ▶ Limit the maximum power input of 1.5 times the rated current to max. 2 minutes (in accordance with EN 60034-1).

**Cycle operation**

Cycle operation with maximum 10 cycles per hour is possible.

Longer operating phases and short downtimes permit a functionally safe operating condition of the vacuum pump.

Operating conditions

- The optimal operating condition of the vacuum pump is continuous operation.
- When pumping down dry gases, no special precautions are required.
- Low final pressures are possible with the gas ballast valve closed.

Switching on vacuum pump

1. If required, switch vacuum pump on in each pressure range.
2. Switch vacuum pump on at mains switch, or, in the case of three-phase motors, on site via a protective circuit.
3. Prior to process start, allow vacuum pump to warm up for approx. 30 minutes with vacuum connection closed.

Checking operating fluid level

1. Regularly check operating fluid level while vacuum pump is running and at operating temperature.
2. Make sure that the fill level is within the markings on the sight glass frame.
3. Check operating fluid fill level daily during continuous operation, and every time vacuum pump is switched on.

6.3 Operating rotary vane pump with gas ballast

NOTICE**Risk of damage from condensation in vacuum pump**

During operation without gas ballast, condensation may form as a result of the vapor compatibility of the vacuum pump being exceeded.

- ▶ Pump condensable vapors only when the vacuum pump is warm and the gas ballast valve open.
- ▶ Allow the vacuum pump to run on after process end for another 30 minutes with the gas ballast valve open.
 - This cleans the operating fluid and protects the vacuum pump against corrosion.

The gas ballast valve supplies air to the working chamber of the vacuum pump periodically at the beginning of the compression phase. When pumping down vapors, this air prevents condensation within certain limits in the vacuum pump.

Behavior with process gases with condensable vapors

- ▶ Operate the vacuum pump with gas ballast, i.e. with the gas ballast valve open.

6.3.1 Gas ballast valve – standard version

i **No intermediate settings possible**
 An intermediate setting between open and closed is not possible.

The gas ballast valve supplies air to the working chamber of the vacuum pump periodically at the beginning of the compression phase. When pumping down vapors, this air prevents condensation within certain limits in the vacuum pump.

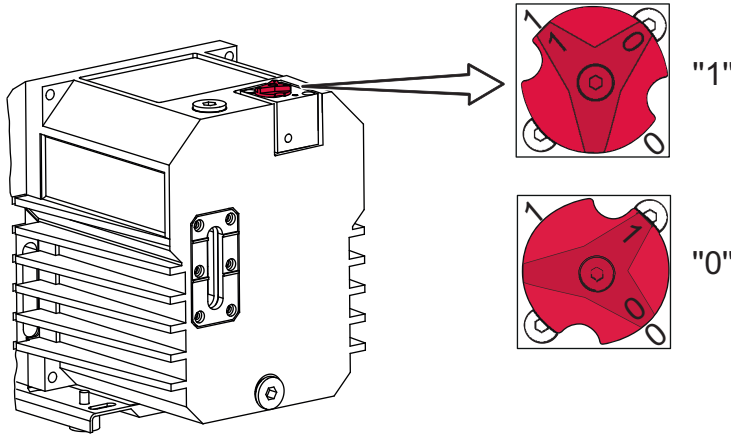

Fig. 13: Gas ballast valve, standard version

Open gas ballast valve

- ▶ Rotate the knob on the gas ballast valve to the left to open, into position "1".

Close gas ballast valve

- ▶ Rotate the knob on the gas ballast valve to the right to close, into position "0".

6.3.2 Gas ballast valve with inert gas connection

NOTICE

Property damage from impermissibly high inert gas pressure
 Increased inert gas pressure compromises operational reliability of the vacuum pump, and causes an increase in power input and operating temperature.

- ▶ Observe the maximum permissible inert gas pressure of **1500 hPa (absolute)**.
- ▶ Dose the inert gas quantity with the dosing screw on the gas ballast valve or on site.

NOTICE

Property damage due to inert gas intake during vacuum pump standstill
 Continued inert gas intake after switching off the vacuum pump will expel the oil film in the pump system, resulting in damage during restart.

- ▶ After switching off the vacuum pump, close the supply of inert gas at the gas ballast valve or by closing the on-site gas supply.

i **No intermediate settings possible**
 An intermediate setting between open and closed is not possible.

For some processes, Pfeiffer Vacuum recommends the addition of inert gas to dilute the process gas and, within certain limits, prevent condensation in the vacuum pump. The inert gas connection is integrated as standard equipment or is a possible option.

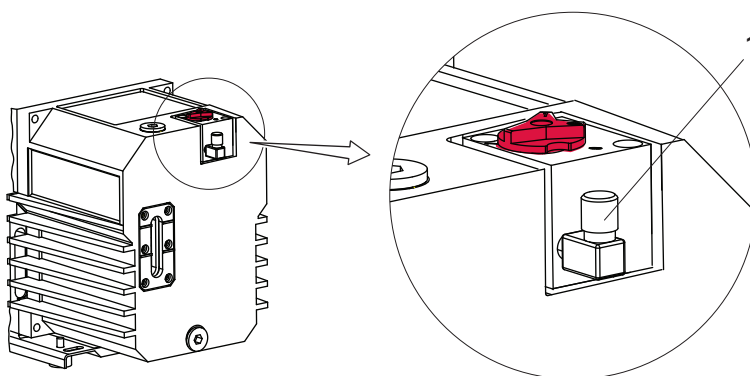

Fig. 14: Gas ballast valve with inert gas connection

- 1 Inert gas connection (M 5) with push-in fitting

Required gas

- Inert gas, e.g. nitrogen (N₂)
- Max. inert gas pressure **1500 hPa (absolute)**
- Max. inert gas quantity **192 l/h**

Required aids

- Hose (external diameter 6 mm)

Required tools

- Open-end wrench, **WAF 7**

Connecting gas ballast valve with inert gas connection

1. Screw in the push-in fitting on the inert gas connection.
2. Connect a hose (external diameter 6 mm) to the inert gas connection, or utilize the M5 threaded connector directly.
3. Select the type and quantity of the inert gas used according to the specific process.
4. Consult Pfeiffer Vacuum if necessary.
5. Set the inert gas pressure.
 - Observe the max. permissible inert gas pressure.
6. Set the desired quantity of inert gas.
 - Observe the max. permissible quantity of inert gas.

Open gas ballast valve

- ▶ Rotate the knob on the gas ballast valve to the left to open, into position “1”.

Close gas ballast valve

- ▶ Rotate the knob on the gas ballast valve to the right to close, into position “0”.

6.4 Refilling operating fluid

⚠ WARNING

Danger of poisoning from toxic vapors

Igniting and heating synthetic operating fluid generates toxic vapors. Danger of poisoning if inhaled.

- ▶ Observe the application instructions and precautions.
- ▶ Do not allow tobacco products to come into contact with the operating fluid.



Recommendation

Refill with operating fluid before the minimum fill level is reached.

Prerequisite

- Vacuum pump switched off

Consumables

- Operating fluid of the vacuum pump

Required tools

- Allen key, **WAF 8**
- Calibrated torque wrench (tightening factor ≤ 2.5)

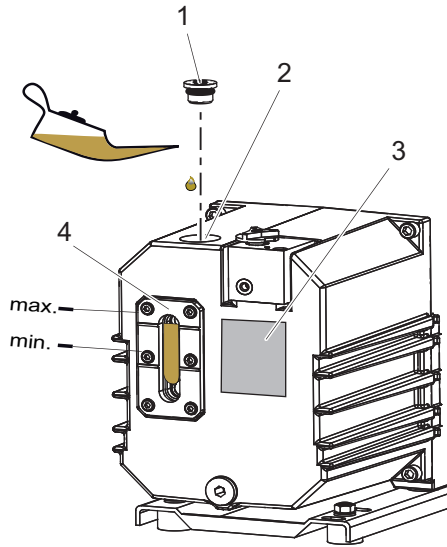

Fig. 15: Refilling operating fluid

- | | |
|----------------------------|----------------|
| 1 Filler screw with o-ring | 3 Rating plate |
| 2 Filler hole | 4 Sight glass |

Procedure

Operating fluid can be refilled during operation in the final vacuum.

1. Unscrew the filler screw.
2. Top up operating fluid up to the “Max.” marking.
3. Screw in the filler screw again.
 - Be careful with the o-ring.
 - Tightening torque: **3.0 Nm**

6.5 Switching off vacuum pump

NOTICE

Contamination from operating fluid backflow

After the vacuum pump is switched off, there is a risk that the connected vacuum system can become contaminated by backflow. The safety valve on the vacuum pump is not suitable for longer-term sealing.

- ▶ Install an additional shut-off valve in the intake line.
- ▶ Shut off the intake line immediately after switching off the vacuum pump.

Procedure

1. If required, switch the vacuum pump off in each pressure range.
2. Switch the mains switch off or securely disconnect the drive motor from the mains.
 - The vacuum safety valve closes automatically when the vacuum pump is switched off, preventing the backflow of gas and operating fluid into the intake line.
3. Install an additional shut-off valve in the intake line to ensure that the vacuum is maintained in the vacuum chamber.

7 Maintenance

7.1 Maintenance instructions

WARNING

Health hazard through poisoning from toxic contaminated components or devices

Toxic process media result in contamination of devices or parts of them. During maintenance work, there is a risk to health from contact with these poisonous substances. Illegal disposal of toxic substances causes environmental damage.

- ▶ Take suitable safety precautions and prevent health hazards or environmental pollution by toxic process media.
- ▶ Decontaminate affected parts before carrying out maintenance work.
- ▶ Wear protective equipment.

WARNING

Tilting danger! Serious injury due to tilting of the product

There is a danger of the vacuum pump not attached tipping over due to changes in the center of gravity or incorrect loading. Serious injuries due to trapping or crushing of limbs, e.g. feet, are the result.

- ▶ Do not use the vacuum pump as a climbing aid.
- ▶ Do not exert any force on the product.
- ▶ Ensure that the product has a safe centre of gravity, when mounting components.
- ▶ Wear protective equipment, e.g. protective shoes

CAUTION

Danger of injury from moving parts

After a power failure or a standstill as a result of overheating, the motor restarts automatically. There is a risk of injury to fingers and hands if they enter the operating range of rotating parts.

- ▶ Safely disconnect motor from the mains.
- ▶ Secure the motor against reactivation.
- ▶ Dismantle the vacuum pump for inspection, away from the system if necessary.

NOTICE

Danger of property damage from improper maintenance

Unprofessional work on the vacuum pump will lead to damage for which Pfeiffer Vacuum accepts no liability.

- ▶ We recommend taking advantage of our service training offering.
- ▶ When ordering spare parts, specify the information on the nameplate.

The following section describes the tasks for cleaning and maintaining the vacuum pump. More advanced works are described in the service instructions.

Prerequisites

- Vacuum pump switched off
- Vacuum pump vented to atmospheric pressure
- Vacuum pump cooled

Preparing maintenance

- ▶ Safely disconnect the drive motor from the mains.
- ▶ Secure the motor against switching back on.
- ▶ For maintenance work, only dismantle the vacuum pump to the extent needed.
- ▶ Dispose of used operating fluid according to applicable regulations in each case.
- ▶ When using synthetic operating fluid, please observe the associated application instructions.
- ▶ Only clean the pump parts using industrial alcohol, isopropanol or similar media.

7.2 Maintenance instructions for magnetic coupling

⚠ WARNING

Danger of injury from strong magnetic field

There is a risk of injury for people with pacemakers and medical implants.

- ▶ Make sure that such individuals do not enter the sphere of influence (≤ 2 m) of the magnetic field.
- ▶ Identify rooms in which magnetic couplings are openly accessible with the symbol: **"No access for people with pacemakers"**.
- ▶ Always keep disassembled couplings away from computers, data carriers, and other electronic components.

This safety note applies to **drive system disassembly** in pump versions with magnetic coupling.

7.3 Checklist for inspection and maintenance

Pfeiffer Vacuum recommends that all maintenance work is carried out by the manufacturer's service department.

No warranty or liability claims are accepted on the part of Pfeiffer Vacuum, if you

- exceed the required, listed intervals
- perform improper maintenance work
- do not use original spare parts

Reduced maintenance intervals

Depending on the operating conditions, the required maintenance intervals can be shorter than the reference values specified.

- ▶ Contact [Pfeiffer Vacuum Service](#).



Spare parts

You can find the corresponding spare parts in the chapter "Spare parts packages" .

Action described in document (OI or MM)	Inspection OI	Maintenance level 1 OI	Maintenance level 2 MM	Maintenance level 3 MM	Required material
Interval	daily	\leq yearly	\leq 2 years	\leq 4 years	
Inspection					
Visual and acoustic pump check Check operating fluid: <ul style="list-style-type: none"> • Check fill level • Check color (contamination) • Check vacuum pump for leaks 	■				
Check accessories (in accordance with operating instructions)	■				
Maintenance level 1 – operating fluid replacement					
Clean the outside of the vacuum pump: <ul style="list-style-type: none"> • Pump housing • Clean motor fan cap Change the operating fluid		■ as required			Operating fluid ²⁾ Maintenance kit 1
Additional activities: <ul style="list-style-type: none"> • Remove cap • Clean inside of cap and outside of pumping system (without cleaning agent) • Remove and clean gas ballast valve, replace wearing parts 		■ as required			

2) Operating fluid is required for all activities. Order operating fluid separately.

Action described in document (OI or MM)	Inspection OI	Maintenance level 1 OI	Maintenance level 2 MM	Maintenance level 3 MM	Required material
Interval	daily	≤ yearly	≤ 2 years	≤ 4 years	
Replace filter in external accessory (where present), in accordance with operating instructions		■ as required			
Maintenance level 3 – overhaul					
Dismantle and clean vacuum pump, replace seals and all wear parts: <ul style="list-style-type: none"> • Vane • Valves, springs, and sight glass • Silencer nozzle 				■	Overhaul kit

Tbl. 7: Maintenance intervals

7.4 Change the operating fluid

WARNING

Health hazard and risk of environmental damage from toxic contaminated operating fluid

Toxic process media can cause operating fluid contamination. When changing the operating fluid, there is a health hazard due to contact with poisonous substances. Illegal disposal of toxic substances causes environmental damage.

- ▶ Wear suitable personal protective equipment when handling these media.
- ▶ Dispose of the operating fluid according to locally applicable regulations.

CAUTION

Scalding from hot operating fluid

Danger of burns when draining operating fluid if it comes into contact with the skin.

- ▶ Wear protective equipment.
- ▶ Use a suitable collection receptacle.



Pfeiffer Vacuum recommends determining the precise service life of the operating fluid within the first maintenance frequency.

The usable life may deviate from the reference value specified depending on thermic and chemical loads, and the accumulation of suspended particles and condensate in the operating fluid.



Operating fluid type

Fundamentally, when filling, refilling, or changing operating fluid, you must always use the operating fluid type specified on the rating plate. Should process conditions change, you can convert to a different operating fluid type.



Safety data sheets

You can obtain the safety data sheets for operating fluids from Pfeiffer Vacuum on request, or from the [Pfeiffer Vacuum Download Center](#).

The usable life of operating fluid is dependent on the area of application of the rotary vane vacuum pumps.

Instructions for when operating fluid should be changed

- Vacuum pump does not reach the specified final pressure.
- Operating fluid soiled, milky or unclear
- Mineral operating fluid with thermic aging (color number > 4)

7.4.1 Determining the degree of aging of P3 operating fluid

⚠ WARNING

Health hazard and risk of environmental damage from toxic contaminated operating fluid

Toxic process media can cause operating fluid contamination. When changing the operating fluid, there is a health hazard due to contact with poisonous substances. Illegal disposal of toxic substances causes environmental damage.

- ▶ Wear suitable personal protective equipment when handling these media.
- ▶ Dispose of the operating fluid according to locally applicable regulations.



Scan this QR code or click [here](#) and view a document that will help you determine the degree of aging of the P3 operating fluid in clean processes using a color chart (according to DIN 51578). The document with the number PK0219 can also be obtained from the [Pfeiffer Vacuum Download Center](#) on request.

Prerequisites

- Vacuum pump switched off
- Vacuum pump is vented to atmospheric pressure on the suction side
- Vacuum pump cooled

Required aids

- Test tube
- Pipette with flexible hose
- Allen key, **WAF 8**
- Calibrated torque wrench (tightening factor ≤ 2.5)

Determine degree of aging of P3 operating fluid

1. Unscrew the filler screw.
 - Be careful with o-ring.
2. Use the pipette to extract a sample of the operating fluid from the filling port.
3. Pour the sample into a test tube.
4. Check the sample in bright light.
5. If it is a reddish-brown color at the latest (corresponding with color identification number 5), change the operating fluid.
6. Screw in the filler screw.
 - Be careful with o-ring.
 - Tightening torque: **3 Nm**

7.4.2 Changing operating fluid

⚠ WARNING

Health hazard and risk of environmental damage from toxic contaminated operating fluid

Toxic process media can cause operating fluid contamination. When changing the operating fluid, there is a health hazard due to contact with poisonous substances. Illegal disposal of toxic substances causes environmental damage.

- ▶ Wear suitable personal protective equipment when handling these media.
- ▶ Dispose of the operating fluid according to locally applicable regulations.

⚠ CAUTION**Scalding from hot operating fluid**

Danger of burns when draining operating fluid if it comes into contact with the skin.

- ▶ Wear protective equipment.
- ▶ Use a suitable collection receptacle.

**Cleaning by changing the operating fluid**

Pfeiffer Vacuum recommends, in cases of heavy contamination with process residues, cleaning the inside of the vacuum pump with several operating fluid changes.

Prerequisites

- Vacuum pump switched off
- Vacuum pump is vented to atmospheric pressure on the suction side
- Vacuum pump cooled down and touchable, operating fluid still warm

Required consumables

- Operating fluid

Required tools

- Allen key, **WAF 6**
- Allen key, **WAF 8**
- Calibrated torque wrench (tightening factor ≤ 2.5)

Required aids

- Collection receptacle (> 1.5 l)

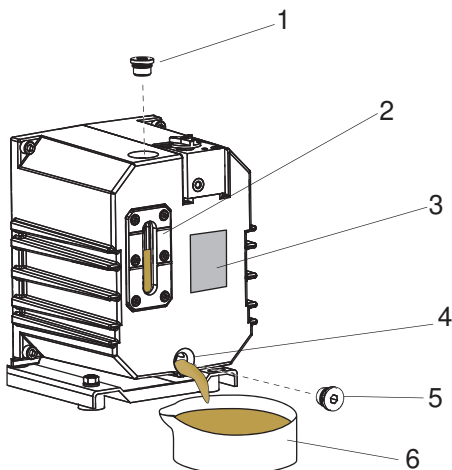

Fig. 16: Draining operating fluid

- | | |
|----------------------------|---------------------------|
| 1 Filler screw with o-ring | 4 Drain hole |
| 2 Sight glass | 5 Drain screw with o-ring |
| 3 Rating plate | 6 Collection receptacle |

Draining the operating fluid

1. Unscrew the filler screw.
 - Be careful with the O-ring.
2. Place a collection receptacle below the drain hole.
3. Unscrew the drain screw.
 - Be careful with the O-ring.
4. Allow operating fluid to drain into collection receptacle.

Agitate remaining operating fluid

1. Screw in the filler screw.
 - Be careful with the O-ring.
2. Screw in the drain screw.
 - Be careful with the O-ring.
3. Switch on the vacuum pump with the vacuum flange open for a maximum of 5 seconds.

Draining remaining operating fluid

1. Unscrew the drain screw.
 - Be careful with the o-ring.
2. Gently tilt the vacuum pump.
3. Drain remaining operating fluid.
4. Screw in the drain screw.
5. Dispose of old operating fluid according to valid regulations.

Fill fresh operating fluid

1. Screw the drain screw in up to the stop.
 - Be careful with the O-ring.
 - Tightening torque: **3.0 Nm**
2. Fill new operating fluid.
3. Check level.
4. Screw the drain screw in completely.
 - Be careful with the O-ring.
 - Tightening torque: **3.0 Nm**

7.4.3 Rinsing and cleaning rotary vane pump



Cleaning by changing the operating fluid

Pfeiffer Vacuum recommends, in cases of heavy contamination with process residues, cleaning the inside of the vacuum pump with several operating fluid changes.

Prerequisite

- Fresh operating fluid filled

Required tools

- Allen key, **WAF 5**
- Allen key, **WAF 6**
- Allen key, **WAF 8**
- Calibrated torque wrench (tightening factor ≤ 2.5)

Required aids

- Collection receptacle (> 0.5 l)

Changing operating fluid for cleaning

1. Operate the vacuum pump with the gas ballast open, until it is warm.
2. Perform an operating fluid change.
3. Check the pollution level and repeat the changing of the operating fluid if necessary.
4. Replace the corresponding filter elements wherever the accessory is installed.

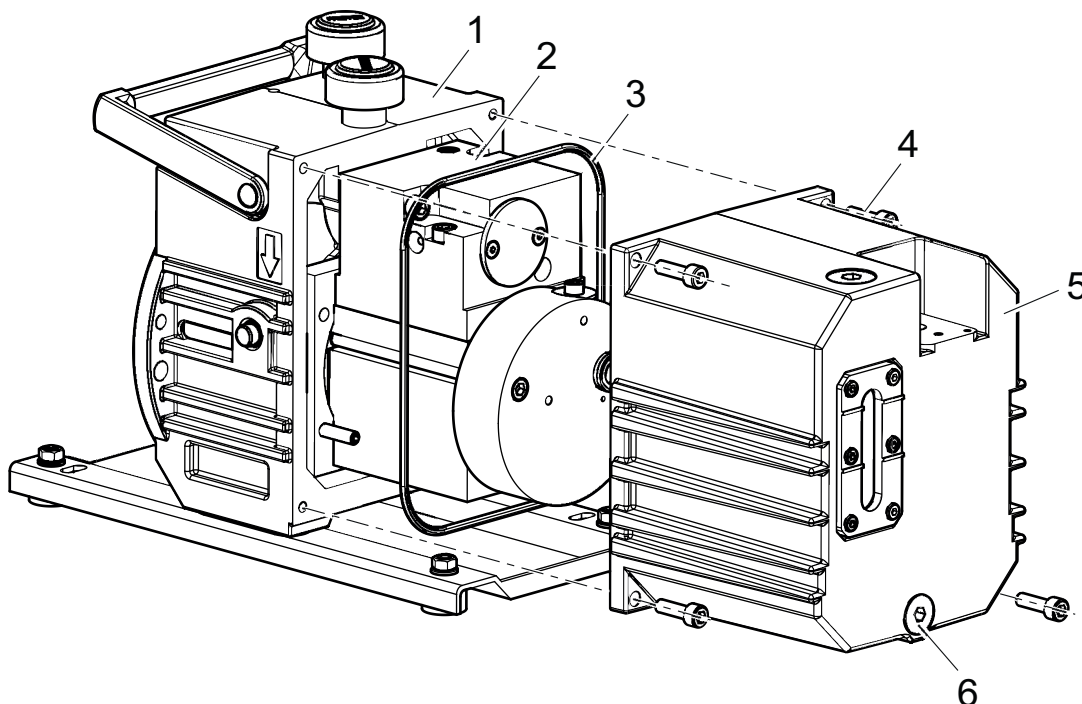

Fig. 17: Removing/fitting the cap on the rotary vane pump

- | | |
|------------------|------------------------|
| 1 Stand | 4 Hexagon socket screw |
| 2 Pumping system | 5 Cap |
| 3 O-ring | 6 Drain screw |

Removing the cap

1. Drain the operating fluid.
2. Unscrew the hexagon socket screws from the cap.
3. Remove the cap from the stand in axial direction.
 - Take care with the o-ring between cap and stand.
4. Collect any leaking operating fluid.
5. Dispose of operating fluid according to applicable regulations.

Cleaning the pumping system and cap

1. Clean the pumping system from the outside without cleaning agent.
2. Clean the cap from the inside without cleaning agent.

Installing the cap

1. Insert the O-ring in the groove in the cap.
2. Install cap on stand.
3. Tighten the hexagon socket screws.
 - Tightening torque: **6.0 Nm**.
4. Screw in the drain screw.
 - Be careful with the o-ring.
 - Tightening torque: **3.0 Nm**
5. Fill with operating fluid and check the fill level.
6. Screw in the filler screw.
 - Be careful with the o-ring.
 - Tightening torque: **3.0 Nm**

Fill fresh operating fluid

1. Screw the drain screw in up to the stop.
 - Be careful with the O-ring.
 - Tightening torque: **3.0 Nm**
2. Fill new operating fluid.
3. Check level.
4. Screw the drain screw in completely.
 - Be careful with the O-ring.
 - Tightening torque: **3.0 Nm**

7.5 Removing and cleaning the gas ballast valve

The gas ballast valve is soiled if the vacuum pump takes in ambient air containing dust.

7.5.1 Removing the gas ballast valve

Required tool

- Allen key, **WAF 3**

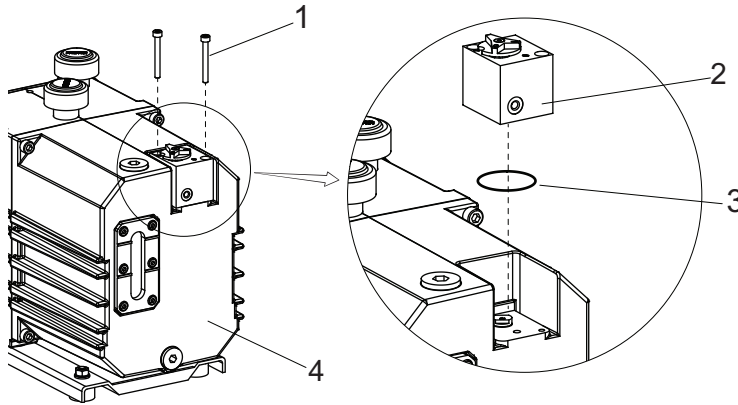

Fig. 18: Removing the gas ballast valve

- | | |
|------------------|----------|
| 1 Cylinder screw | 3 O-ring |
| 2 Valve housing | 4 Cap |

Procedure

1. Unscrew cylinder screws.
2. Remove valve housing from cover.
3. Be careful with the o-ring.

7.5.2 Disassembling and cleaning gas ballast valve

Required tools

- Allen key, **WAF 2**
- Allen key, **WAF 3**
- Snap ring pliers, **J0**

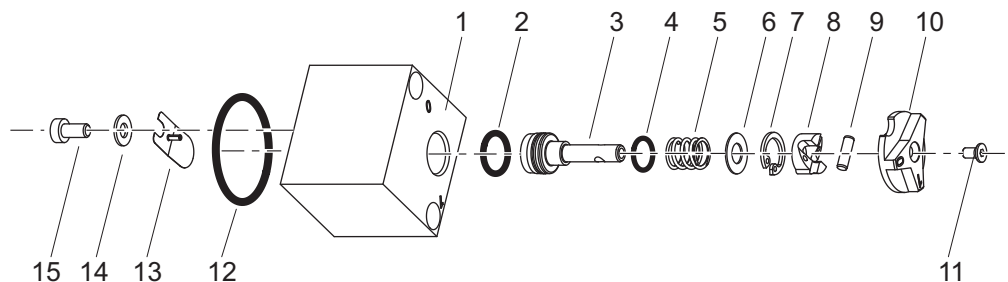

Fig. 19: Individual parts of the gas ballast valve

- | | |
|----------------------|----------------------|
| 1 Valve housing | 9 Cylinder bolt |
| 2 O-ring 6 × 2.2 | 10 Rotary knob |
| 3 Tappet | 11 Countersink screw |
| 4 O-ring 8 × 2 | 12 O-ring 27 × 2.5 |
| 5 Compression spring | 13 Plate spring |
| 6 Washer | 14 Washer |
| 7 Circlip | 15 Cylinder screw |
| 8 Cam plate | |

Procedure

1. Unscrew the cylinder screw from the bottom side of the valve housing.
 - Be careful with the washer and leaf spring.
2. Leave the dowel pin in the valve housing.
3. Rotate knob to “open” position.

4. Unscrew countersunk head screws.
5. Remove rotary knob.
6. Pull the tappet far enough out of the valve housing so that you can pull out the cylinder pin.
7. Remove the cam plate and the circlip using pincers.
8. Be careful with washer and compression spring.
9. Remove tappet from valve housing.
 - Be careful with the o-ring.
10. Clean all parts and check parts for wear.
11. Replace wear parts according to maintenance kit.

7.5.3 Remove and clean silencer nozzle

The silencer nozzle is installed below the gas ballast valve. The nozzle has a type-specific opening. If the nozzle is soiled, it must be cleaned or replaced.

Required tool

- Open-end wrench, **WAF 8**

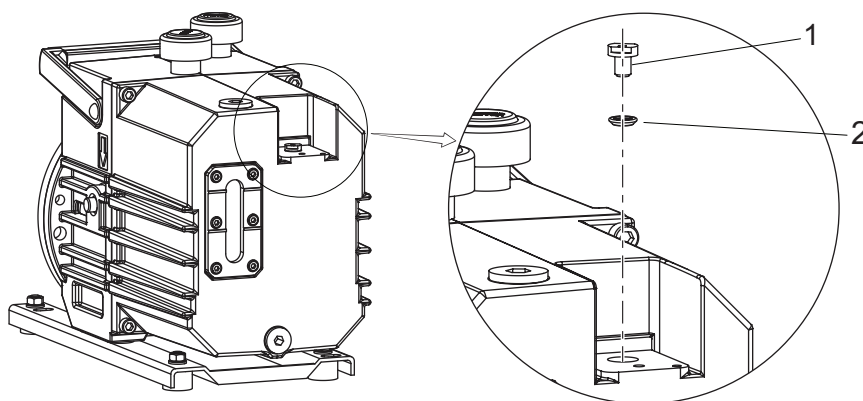

Fig. 20: Remove silencer nozzle

- | | |
|-------------------|------------------|
| 1 Silencer nozzle | 2 O-ring 6 × 2.2 |
|-------------------|------------------|

Procedure

1. Unscrew silencer nozzle.
 - Be careful with the o-ring.
2. Clean silencer nozzle with compressed air.
3. Screw silencer nozzle back in up to stop.
 - Be careful with the o-ring.

7.5.4 Install gas ballast valve

Required tools

- Allen key, **WAF 2**
- Allen key, **WAF 3**
- Circlip pliers, **J0**
- Calibrated torque wrench (tightening factor ≤ 2.5)

Required consumables

- Operating fluid of rotary vane pump

Procedure

1. Wet the o-rings slightly with the operating fluid used.
2. Insert the o-ring evenly into the groove of the tappet.
3. Install the second o-ring on the tappet.
4. Install compression spring and washer.
5. Insert pre-assembled parts in valve housing.
6. Press the washer down against the spring force.
7. Insert the circlip in the recess of the valve housing until it engages.
8. Slide the cam plate onto the tappet.
 - Take care with longitudinal groove in flange housing.

9. Extract tappet, against spring force.
10. Insert cylinder bolt in bore.
11. Rotate cam plate to move tappet to "1" position (open).
12. Install knob to tappet.
13. Tighten countersunk head screws.
 - Tightening torque: **1.0 Nm**.
14. Position leaf spring on dowel pin (curvature facing housing).
15. Bias and fixate leaf spring with cylinder screw and washer.
 - Tightening torque: **2.5 Nm**.
16. Install the complete valve with o-ring in the vacuum pump.
17. Tighten the cylinder screws.
 - Tightening torque: **2.5 Nm**.

7.6 Changing the operating fluid type



Possibilities for changing the operating fluid type

The operating fluid type can be changed between mineral operating fluid – **P3** – and synthetic operating fluid – **D2** – only.

It is not possible to change from **P3/D2** to **F4/F5** or vice versa.

Required consumables

- 3 times the filling quantity of the new operating fluid

Changing the operating fluid type

1. Change the operating fluid with the new operating fluid **twice** in order to rinse the vacuum pump.
2. Clean any accessories if necessary, such as oil mist filter or oil return, and replace their filter elements.
3. Fill the vacuum pump with operating fluid to one third full.
4. Note the currently used operating fluid type at a suitable location on the vacuum pump, e.g. on the rating plate.

8 Decommissioning

8.1 Shutting down for longer periods

Before shutting down the vacuum pump, observe the following instructions to adequately protect the interior of the vacuum pump (suction chamber) from corrosion:

Procedure

1. Switch off the vacuum pump.
2. Vent the vacuum pump.
3. Allow the vacuum pump to cool down.
4. Change the operating fluid.
5. Start the vacuum pump and take it up to operating temperature in order to wet the inside of the pumping system with fresh operating fluid.
6. Fill the vacuum pump to above the “**max.**” mark with operating fluid, up to the upper edge of the sight glass.
7. Seal the vacuum and exhaust flanges as well as any other openings with blank flanges from the Pfeiffer Vacuum [accessories range](#).
8. Store the vacuum pump in dry, dust-free rooms, within the specified ambient conditions.
9. Pack the vacuum pump together with a drying agent in a plastic bag, and seal the vacuum pump airtight if it is to be stored in rooms with damp or aggressive atmospheres.
10. For longer storage periods (> 2 years), Pfeiffer Vacuum recommends changing the operating fluid again prior to recommissioning.

8.2 Recommissioning

NOTICE

Risk of damage to vacuum pump as a result of operating fluid aging

The operating fluid usability is limited (max. 2 years). Prior to recommissioning, following a shutdown of **2 years or more**, carry out the following work.

- ▶ Change the operating fluid.
- ▶ Change the radial shaft seal rings and other elastomer parts if required.
- ▶ Observe the maintenance instructions – consult Pfeiffer Vacuum if necessary.



Ejection of operating fluid

Overfilled operating fluid will be ejected at the exhaust connection when starting up the vacuum pump.

- Reduce the operating fluid level to the normal level before recommissioning.

9 Recycling and disposal

WARNING

Health hazard through poisoning from toxic contaminated components or devices

Toxic process media result in contamination of devices or parts of them. During maintenance work, there is a risk to health from contact with these poisonous substances. Illegal disposal of toxic substances causes environmental damage.

- ▶ Take suitable safety precautions and prevent health hazards or environmental pollution by toxic process media.
- ▶ Decontaminate affected parts before carrying out maintenance work.
- ▶ Wear protective equipment.



Environmental protection

You **must** dispose of the product and its components in accordance with all applicable regulations for protecting people, the environment and nature.

- Help to reduce the wastage of natural resources.
- Prevent contamination.

9.1 General disposal information

Pfeiffer Vacuum products contain materials that you must recycle.

- ▶ Dispose of our products according to the following:
 - Iron
 - Aluminium
 - Copper
 - Synthetic
 - Electronic components
 - Oil and fat, solvent-free
- ▶ Observe the special precautionary measures when disposing of:
 - Fluoroelastomers (FKM)
 - Potentially contaminated components that come into contact with media

9.2 Dispose of rotary vane pump

Pfeiffer Vacuum rotary vane pumps contain materials that you must recycle.

1. Fully drain the lubricant.
2. Dismantle the motor.
3. Decontaminate the components that come into contact with process gases.
4. Separate the components into recyclable materials.
5. Recycle the non-contaminated components.
6. Dispose of the product or components in a safe manner according to locally applicable regulations.

10 Malfunctions

⚠ CAUTION

Risk of injury from entrapment of body parts

After a power failure or a standstill as a result of overheating, the motor restarts automatically. A risk exists of minor injury to fingers and hands (e.g., hematoma), from direct contact with the vacuum flange.

- ▶ Maintain sufficient distance to the vacuum flange during all work.
- ▶ Safely disconnect motor from the mains.
- ▶ Secure the motor against re-start.

⚠ CAUTION

Danger of burns on hot surfaces

In the event of a fault, the surface temperature of the vacuum pump can increase to above 105 °C.

- ▶ Allow the vacuum pump to cool down before carrying out any work.
- ▶ Wear personal protective equipment if necessary.

⚠ CAUTION

Danger of injury from moving parts

After a power failure or a standstill as a result of overheating, the motor restarts automatically. There is a risk of injury to fingers and hands if they enter the operating range of rotating parts.

- ▶ Safely disconnect motor from the mains.
- ▶ Secure the motor against reactivation.
- ▶ Dismantle the vacuum pump for inspection, away from the system if necessary.

NOTICE

Danger of property damage from improper maintenance

Unprofessional work on the vacuum pump will lead to damage for which Pfeiffer Vacuum accepts no liability.

- ▶ We recommend taking advantage of our service training offering.
- ▶ When ordering spare parts, specify the information on the nameplate.

Should malfunctions occur, you can find information about potential causes and how to fix them here:

Problem	Possible causes	Remedy
Vacuum pump will not start up	<ul style="list-style-type: none"> ● No mains voltage or voltage does not correspond to the motor data 	<ul style="list-style-type: none"> ● Check the mains voltage and mains fuse. ● Check the motor switch.
	<ul style="list-style-type: none"> ● Pump temperature too low 	<ul style="list-style-type: none"> ● Heat the vacuum pump to > 12°C.
	<ul style="list-style-type: none"> ● Thermal protection switch has triggered 	<ul style="list-style-type: none"> ● Determine and eliminate the cause. ● Allow the vacuum pump to cool down.
	<ul style="list-style-type: none"> ● Pumping system contaminated 	<ul style="list-style-type: none"> ● Clean the vacuum pump. ● Contact Pfeiffer Vacuum Service.
	<ul style="list-style-type: none"> ● Pumping system damaged 	<ul style="list-style-type: none"> ● Clean and maintain the vacuum pump. ● Contact Pfeiffer Vacuum Service.
	<ul style="list-style-type: none"> ● Motor faulty 	<ul style="list-style-type: none"> ● Replace the motor.

Problem	Possible causes	Remedy
Vacuum pump switches off after a while after being started	<ul style="list-style-type: none"> Thermal protection switch of the motor has triggered 	<ul style="list-style-type: none"> Determine and eliminate the cause of overheating. Allow the motor to cool down.
	<ul style="list-style-type: none"> Mains fuse triggered due to overload (e.g. cold start) 	<ul style="list-style-type: none"> Bring vacuum pump to permissible ambient temperature range.
	<ul style="list-style-type: none"> Exhaust pressure too high 	<ul style="list-style-type: none"> Check exhaust line outlet opening and exhaust side accessories.
Vacuum pump does not reach the specified final pressure	<ul style="list-style-type: none"> Measurement result distorted 	<ul style="list-style-type: none"> Check the measurement instrument. Check the final pressure without system connected.
	<ul style="list-style-type: none"> Vacuum pump or connected accessory contaminated 	<ul style="list-style-type: none"> Clean the vacuum pump. Check the components for contamination.
	<ul style="list-style-type: none"> Operating fluid contaminated 	<ul style="list-style-type: none"> Operate the vacuum pump for an extended period of time with gas ballast valve open, or change the operating fluid.
	<ul style="list-style-type: none"> Operating fluid level too low 	<ul style="list-style-type: none"> Top up the operating fluid.
	<ul style="list-style-type: none"> Leak in system 	<ul style="list-style-type: none"> Locate and eliminate the leak.
	<ul style="list-style-type: none"> Vacuum pump is damaged 	<ul style="list-style-type: none"> Contact Pfeiffer Vacuum Service.
	<ul style="list-style-type: none"> The intake line is not suitably dimensioned 	<ul style="list-style-type: none"> Make sure that connections are short and cross sections adequately dimensioned.
Pumping speed of vacuum pump too low	<ul style="list-style-type: none"> Exhaust pressure too high 	<ul style="list-style-type: none"> Check exhaust line outlet opening and exhaust side accessories.
	<ul style="list-style-type: none"> The intake line is not suitably dimensioned 	<ul style="list-style-type: none"> Make sure that connections are short and cross sections adequately dimensioned.
Loss of operating fluid	<ul style="list-style-type: none"> Casing seal is leaking 	<ul style="list-style-type: none"> Check and replace the seal.
	<ul style="list-style-type: none"> Radial shaft seal ring (RSSR) leaking – not applicable to vacuum pumps with magnetic coupling 	<ul style="list-style-type: none"> Check and replace the RSSR Check and replace the associated bushing also.
	<ul style="list-style-type: none"> Operational operating fluid loss – no oil mist filter 	<ul style="list-style-type: none"> Install ONF/OME.
Unusual noises during operation	<ul style="list-style-type: none"> Noise reduction is contaminated 	<ul style="list-style-type: none"> Clean the noise reduction or replace it.
	<ul style="list-style-type: none"> Pumping system is contaminated or damaged 	<ul style="list-style-type: none"> Clean and maintain the vacuum pump. Contact Pfeiffer Vacuum Service.
	<ul style="list-style-type: none"> Motor bearing is faulty 	<ul style="list-style-type: none"> Change the motor. Contact Pfeiffer Vacuum Service.

Tbl. 8: Troubleshooting for rotary vane pumps

11 Service solutions by Pfeiffer Vacuum

We offer first-class service

High vacuum component service life, in combination with low downtime, are clear expectations that you place on us. We meet your needs with efficient products and outstanding service.

We are always focused on perfecting our core competence – servicing of vacuum components. Once you have purchased a product from Pfeiffer Vacuum, our service is far from over. This is often exactly where service begins. Obviously, in proven Pfeiffer Vacuum quality.

Our professional sales and service employees are available to provide you with reliable assistance, worldwide. Pfeiffer Vacuum offers an entire range of services, from [original replacement parts](#) to [service contracts](#).

Make use of Pfeiffer Vacuum service

Whether preventive, on-site service carried out by our field service, fast replacement with mint condition replacement products, or repair carried out in a [Service Center](#) near you – you have various options for maintaining your equipment availability. You can find more detailed information and addresses on our homepage, in the [Pfeiffer Vacuum Service](#) section.

You can obtain advice on the optimal solution for you, from your [Pfeiffer Vacuum representative](#).

For fast and smooth service process handling, we recommend the following:



1. Download the up-to-date form templates.
 - [Explanations of service requests](#)
 - [Service requests](#)
 - [Contamination declaration](#)



- a) Remove and store all accessories (all external parts, such as valves, protective screens, etc.).
 - b) If necessary, drain operating fluid/lubricant.
 - c) If necessary, drain coolant.
2. Complete the service request and contamination declaration.



3. Send the forms by email, fax, or post to your local [Service Center](#).



4. You will receive an acknowledgment from Pfeiffer Vacuum.

PFEIFFER VACUUM

Submission of contaminated products

No microbiological, explosive, or radiologically contaminated products will be accepted. Where products are contaminated, or the contamination declaration is missing, Pfeiffer Vacuum will contact you before starting service work. Depending on the product and degree of pollution, **additional decontamination costs** may be incurred.

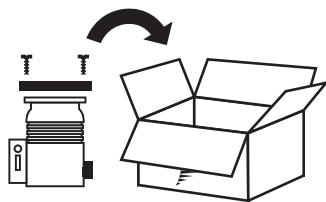

5. Prepare the product for transport in accordance with the provisions in the contamination declaration.
 - a) Neutralize the product with nitrogen or dry air.
 - b) Seal all openings with blind flanges, so that they are airtight.
 - c) Shrink-wrap the product in suitable protective foil.
 - d) Package the product in suitable, stable transport containers only.
 - e) Maintain applicable transport conditions.

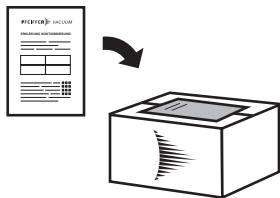

6. Attach the contamination declaration to the **outside** of the packaging.

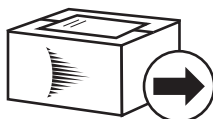

7. Now send your product to your local Service Center.

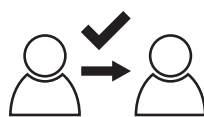

8. You will receive an acknowledgment/quotation, from Pfeiffer Vacuum.

PFEIFFER VACUUM

Our sales and delivery conditions and repair and maintenance conditions for vacuum devices and components apply to all service orders.

12 Spare parts

12.1 Spare part packages

Ordering spare part packages

- ▶ Have the vacuum pump part number to hand, along with other details from the rating plate if necessary.
- ▶ Install original spare parts only.
- ▶ When ordering the inspection set, observe the respective part number of the diaphragm pump.

Spare part package	Pump version	Order number
Maintenance kit 1 – maintenance level 1	M/MC version	PK E31 004 AT
Overhaul kit – maintenance level 3	M version	PK E32 008 -T
	MC version	PK E32 006 -T
Set of vanes	M version	PK E38 008 -T
	MC version	PK E38 009 -T
Coupling set	M version	PK E36 005 -T
	MC version	PK E36 006 -T

Tbl. 9: Spare part packages

12.2 Maintenance kit 1 – maintenance level 1

Order no.: PK E31 004 AT

Maintenance kit 1 contains:

- Filler and drain screw seals for one operating fluid change
- Cap seal for cleaning the oil chamber
- Seals and consumables for cleaning the gas ballast valve

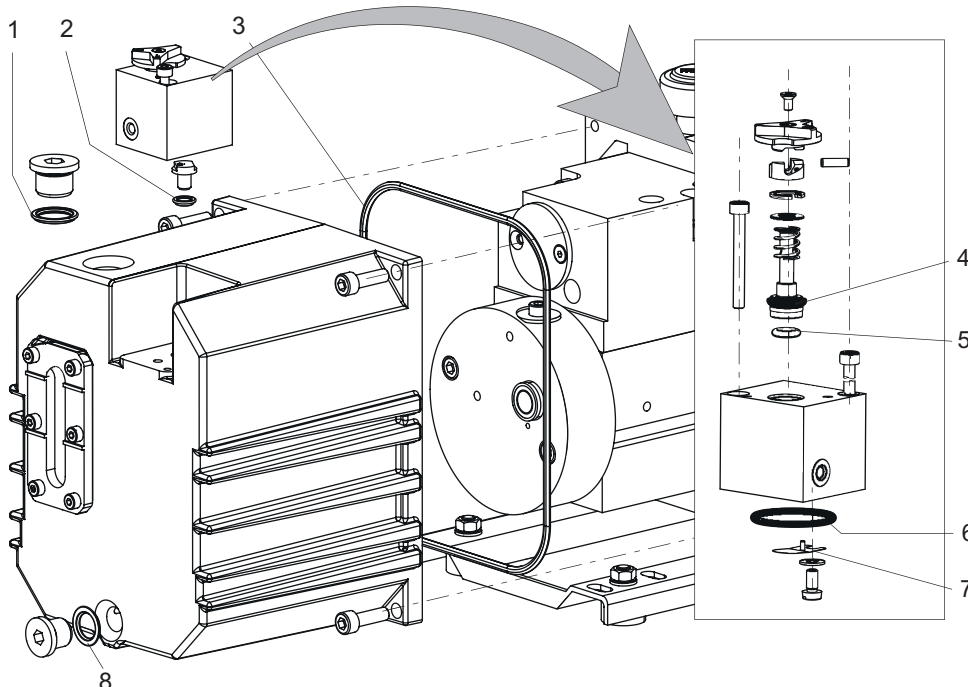

Fig. 21: Content of maintenance kit 1 – maintenance level 1

Item no.	Designation	Size	Shipment
1	O-ring, FPM	15 × 2.5	1
2, 5	O-ring, FPM	6 × 2.2	2
3	O-ring, FPM	165 × 3.0	1
4	O-ring, FPM	8 × 2.0	1
6	O-ring, FPM	27 × 2.5	2
7	Plate spring		1
8	O-ring, FPM	10 × 2.5	1

Tbl. 10: Content of maintenance kit 1

12.3 Overhaul kit – Maintenance level 3

The overhaul kit contains all the **wear parts** of the vacuum pump, which must be replaced after the vacuum pump has been dismantled and cleaned:

- Set of seals
- Wear parts of the pumping system (including vane and springs)
- Wear parts of the vacuum safety valve
- Wear parts of the gas ballast valve

12.4 Coupling set for versions with magnetic coupling

The coupling set contains:

- Both coupling halves
- Containment shell with O-ring

12.5 Set of vanes

The set of vanes contains:

- Vane
- Vane springs

13 Accessories

13.1 Accessory information

Dust separators

Protects the pump against particles from the processes

Condensate separator

Protects the pump from liquids from intake line or condensate return flow from the exhaust line

Oil mist filter

Prevents oil mist from escaping

Oil return

Guides separated operating fluid from the oil mist filter back into the rotary vane vacuum pump

Activated carbon filter

When mounted on the intake side, protects the vacuum pump and operating fluid against gaseous inorganic contaminants such as acids and lyes

Catalyser trap

Prevents backflow of operating fluid vapors (mineral oil only) into the vacuum equipment by separating the oil molecules into CO₂ and water

Sorption trap

Use an absorption medium with an extremely porous surface to absorb water or hydrocarbon from the pumped gas

Cooling trap

For cooling, e.g. with liquid nitrogen. Prevents backflow of any operating fluid vapors through condensation and protects the vacuum pump and operating fluid against vapors from the process

PTC resistor tripping device

Monitors the temperature of the motor winding

Process monitoring unit

Monitors the operating fluid level, operating fluid temperature, exhaust pressure

Shut-off valve

For manual shut-off of the intake line to the vacuum system in the event of a long standstill of the vacuum pump.

13.2 Order accessories

Description	Order number
PTC Resistor tripping device 24 V AC/DC	P 4768 052 FE
PTC Resistor tripping device 220 – 240 V AC	P 4768 052 FQ
Operations monitoring unit 1	PK 196 148 -T
Operations monitoring unit 2	PK 196 147 -T
Operations monitoring unit 3	PK 196 146 -T
Oil pressure switch	PK 196 484 -T
KAS 16, Condensate separator	PK Z10 003
OME 16 S, oil mist separator	PK Z40 000
Oil return unit from OME 16 S to Duo 5 M/Duo 10 M	PK 005 987 -T
OME 16 M, oil mist separator	PK Z40 003
Oil return unit ODK from OME 16 M to Duo 5 M, from OME 25 M to Duo 10 M, from OME 25 ML in Duo 20 M	PK 196 172 -T
SAS 16, dust separator	PK Z60 506
ZFO 16, Zeolite Trap	PK Z70 003

Description	Order number
Push-in L-fitting, M5 A for tube 6 mm	P 0996 105
Blank flange, gas ballast valve	PK 196 391 -T

Tbl. 11: Accessories for Duo 5 M

Description	Order number
PTC Resistor tripping device 24 V AC/DC	P 4768 052 FE
PTC Resistor tripping device 220 – 240 V AC	P 4768 052 FQ
Operations monitoring unit 3	PK 196 146 -T
Operations monitoring unit 2	PK 196 147 -T
Operations monitoring unit 1	PK 196 148 -T
Oil pressure switch	PK 196 484 -T
OME 16 C, oil mist separator	PK Z40 400
Oil return unit from OME 16 S to Duo 5 M/Duo 10 M	PK 005 987 -T
Blank flange, gas ballast valve	PK 196 391 -T

Tbl. 12: Accessories for Duo 5 MC

Selection field	Part number
P3, mineral oil, 1 l	PK 001 106 -T
P3, mineral oil, 5 l	PK 001 107 -T
P3, mineral oil, 20 l	PK 001 108 -T
D1, synthetic diester based oil, 1 l	PK 005 875 -T
D1, synthetic diester based oil, 5 l	PK 005 876 -T
F4, Perfluoropolyether, 0.25 l	PK 005 885 -T
F4, Perfluoropolyether, 0.5 l	PK 005 886 -T
F4, Perfluoropolyether, 1 l	PK 005 887 -T
F4, Perfluoropolyether, 5 l	PK 005 888 -T

Tbl. 13: Consumables

14 Technical data and dimensions

14.1 General

Basis for the technical data of Pfeiffer Vacuum rotary vane pumps:

- Specifications according to PNEUROP committee PN5
- ISO 21360-1: 2016: "Vacuum technology - Standard methods for measuring vacuum-pump performance - Part 1: General description"
- Leak test to ascertain the integral leakage rate according to EN 1779: 1999 technique A1; with 20 % helium concentration, 10 s measurement duration
- Sound pressure level according to ISO 3744, class 2

	mbar	bar	Pa	hPa	kPa	Torr mm Hg
mbar	1	$1 \cdot 10^{-3}$	100	1	0.1	0.75
bar	1000	1	$1 \cdot 10^5$	1000	100	750
Pa	0.01	$1 \cdot 10^{-5}$	1	0.01	$1 \cdot 10^{-3}$	$7.5 \cdot 10^{-3}$
hPa	1	$1 \cdot 10^{-3}$	100	1	0.1	0.75
kPa	10	0.01	1000	10	1	7.5
Torr mm Hg	1.33	$1.33 \cdot 10^{-3}$	133.32	1.33	0.133	1

$$1 \text{ Pa} = 1 \text{ N/m}^2$$

Tbl. 14: Conversion table: Pressure units

	mbar l/s	Pa m ³ /s	sccm	Torr l/s	atm cm ³ /s
mbar l/s	1	0.1	59.2	0.75	0.987
Pa m ³ /s	10	1	592	7.5	9.87
sccm	$1.69 \cdot 10^{-2}$	$1.69 \cdot 10^{-3}$	1	$1.27 \cdot 10^{-2}$	$1.67 \cdot 10^{-2}$
Torr l/s	1.33	0.133	78.9	1	1.32
atm cm ³ /s	1.01	0.101	59.8	0.76	1

Tbl. 15: Conversion table: Units for gas throughput

14.2 Substances in contact with the media

Pump parts	Materials in contact with the media	M Version	MC Version
Housing	Aluminum	X	X
Inlet/exhaust flange	Stainless steel	X	X
Sight glass	Float glass	X	X
Stator/stator flanges	Cast iron	X	X
Rotor	Cast iron (nodular graphite cast iron)	X	X
Magnetic coupling	Steel, nickel-coated magnets	X	-
	Steel, stainless steel	-	X
Vane	Artificial resin compound, polymer	X	-
	Composite, polymer	-	X
Exhaust valve	Stainless steel	X	X
Vacuum safety valve	Aluminum, steel, FKM	X	X
Gas ballast valve	Aluminum, stainless steel, FKM	X	X
Screws	Galvanized steel, stainless steel	X	X

Pump parts	Materials in contact with the media	M Version	MC Version
Seals	FKM	X	X
Containment shell	Stainless steel	X	X

Tbl. 16: Materials that make contact with the process media

14.3 Technical data

Type designation	Duo 5 M	Duo 5 M	Duo 5 M	Duo 5 M	Duo 5 M
Part number	PK D61 105	PK D61 707	PK D61 712	PK D61 712	PK D61 017
Connection flange (in)	DN 16 ISO-KF	DN 16 ISO-KF	DN 16 ISO-KF	DN 16 ISO-KF	DN 25 ISO-KF
Connection flange (out)	DN 16 ISO-KF	DN 16 ISO-KF	DN 16 ISO-KF	DN 16 ISO-KF	–
Pumping speed at 50 Hz	5 m ³ /h	5 m ³ /h	5 m ³ /h	5 m ³ /h	5 m ³ /h
Pumping speed at 60 Hz	6 m ³ /h	6 m ³ /h	6 m ³ /h	6 m ³ /h	6 m ³ /h
Final pressure with gas ballast	7 · 10 ⁻³ hPa	7 · 10 ⁻³ hPa	7 · 10 ⁻³ hPa	7 · 10 ⁻³ hPa	7 · 10 ⁻³ hPa
Final pressure	4 · 10 ⁻³ hPa	4 · 10 ⁻³ hPa	4 · 10 ⁻³ hPa	4 · 10 ⁻³ hPa	4 · 10 ⁻³ hPa
Gas ballast flow	192 l/h	192 l/h	192 l/h	192 l/h	192 l/h
Water vapor capacity 50 Hz	44 g/h	44 g/h	44 g/h	44 g/h	44 g/h
Water vapor capacity 60 Hz	53 g/h	53 g/h	53 g/h	53 g/h	53 g/h
Water vapor tolerance at 50 Hz	13 hPa	13 hPa	13 hPa	13 hPa	13 hPa
Water vapor tolerance at 60 Hz	14 hPa	14 hPa	14 hPa	14 hPa	14 hPa
Leakage rate safety valve	≤ 1 · 10 ⁻⁵ Pa m ³ /s	≤ 1 · 10 ⁻⁵ Pa m ³ /s	≤ 1 · 10 ⁻⁵ Pa m ³ /s	≤ 1 · 10 ⁻⁵ Pa m ³ /s	≤ 1 · 10 ⁻⁵ Pa m ³ /s
Exhaust pressure, min.	250 hPa	250 hPa	250 hPa	250 hPa	250 hPa
Exhaust pressure, max.	1500 hPa	1500 hPa	1500 hPa	1500 hPa	1500 hPa
Emission sound pressure level without gas ballast at 50 Hz	≤ 55 dB(A)	≤ 57 dB(A)	≤ 57 dB(A)	≤ 57 dB(A)	≤ 57 dB(A)
Cooling method	Air (Forced convection)	Air (Forced convection)	Air (Forced convection)	Air (Forced convection)	Air (Forced convection)
Operating fluid amount	0.75 l	0.75 l	0.75 l	0.75 l	0.75 l
Ambient temperature	12 – 40 °C	12 – 40 °C	12 – 40 °C	12 – 40 °C	12 – 40 °C
Shipping and storage temperature	-25 – 55 °C	-25 – 55 °C	-25 – 55 °C	-25 – 55 °C	-25 – 55 °C
Motor type	3-phase motor	1-phase motor	1-phase motor	1-phase motor	1-phase motor
Motor protection	PTC	Bimetal	Bimetal	Bimetal	Bimetal
Input voltage 50 Hz	220 – 240 / 380 – 420 V	95 – 120 V	200 – 240 V	220 – 240 V	220 – 240 V

Type designation	Duo 5 M	Duo 5 M	Duo 5 M	Duo 5 M	Duo 5 M
Input voltage 60 Hz	250 – 277 / 440 – 480 V	105 – 120 V	208 – 240 V	220 – 240 V	220 – 240 V
Input voltage: tolerance	±5 %	±5 %	±5 %	±5 %	±5 %
Rated power 50 Hz	0.25 kW	0.37 kW	0.37 kW	0.37 kW	0.37 kW
Rated power 60 Hz	0.3 kW	0.37 kW	0.37 kW	0.37 kW	0.37 kW
Rotation speed at 50 Hz	1500 rpm	1500 rpm	1500 rpm	1500 rpm	1500 rpm
Rotation speed at 60 Hz	1800 rpm	1800 rpm	1800 rpm	1800 rpm	1800 rpm
Magnetic coupling	Yes	Yes	Yes	Yes	Yes
Protection degree	IP55	IP55	IP55	IP54	IP54
Switch	No	Yes	Yes	Yes	Yes
Mains cable	No	Yes	Yes	Yes	Yes
Mains cable included	No	Yes	Yes	Yes	Yes
Weight	19 kg	25 kg	25 kg	22 kg	22 kg
Certification	CE	CE	CE	CE	CE

Tbl. 17: Technical data Duo 5 M

Type designation	Duo 5 MC	Duo 5 MC
Part number	PK D61 727	PK D61 732
Connection flange (in)	DN 16 ISO-KF	DN 16 ISO-KF
Connection flange (out)	DN 16 ISO-KF	DN 16 ISO-KF
Pumping speed at 50 Hz	5 m ³ /h	5 m ³ /h
Pumping speed at 60 Hz	6 m ³ /h	6 m ³ /h
Final pressure with gas ballast	1.2 · 10 ⁻² hPa	1.2 · 10 ⁻² hPa
Final pressure	5 · 10 ⁻³ hPa	5 · 10 ⁻³ hPa
Leakage rate safety valve	≤ 1 · 10 ⁻⁵ Pa m ³ /s	≤ 1 · 10 ⁻⁵ Pa m ³ /s
Exhaust pressure, min.	250 hPa	250 hPa
Exhaust pressure, max.	1500 hPa	1500 hPa
Emission sound pressure level without gas ballast at 50 Hz	≤ 57 dB(A)	≤ 57 dB(A)
Cooling method	Air (Forced convection)	Air (Forced convection)
Operating fluid amount	0.75 l	0.75 l
Ambient temperature	12 – 40 °C	12 – 40 °C
Shipping and storage temperature	-25 – 55 °C	-25 – 55 °C
Motor type	1-phase motor	1-phase motor
Input voltage 50 Hz	95 – 120 V	200 – 240 V
Input voltage 60 Hz	105 – 120 V	208 – 240 V
Input voltage: tolerance	±5 %	±5 %
Rated power 50 Hz	0.37 kW	0.37 kW
Rated power 60 Hz	0.37 kW	0.37 kW
Rotation speed at 50 Hz	1500 rpm	1500 rpm
Rotation speed at 60 Hz	1800 rpm	1800 rpm
Magnetic coupling	Yes	Yes
Corrosive gas version	Yes	Yes

Type designation	Duo 5 MC	Duo 5 MC
Protection degree	IP55	IP55
Switch	Yes	Yes
Mains cable	Yes	Yes
Mains cable included	Yes	Yes
Weight	25 kg	25 kg
Certification	CE	CE

Tbl. 18: Technical data Duo 5 MC

14.4 Dimensions

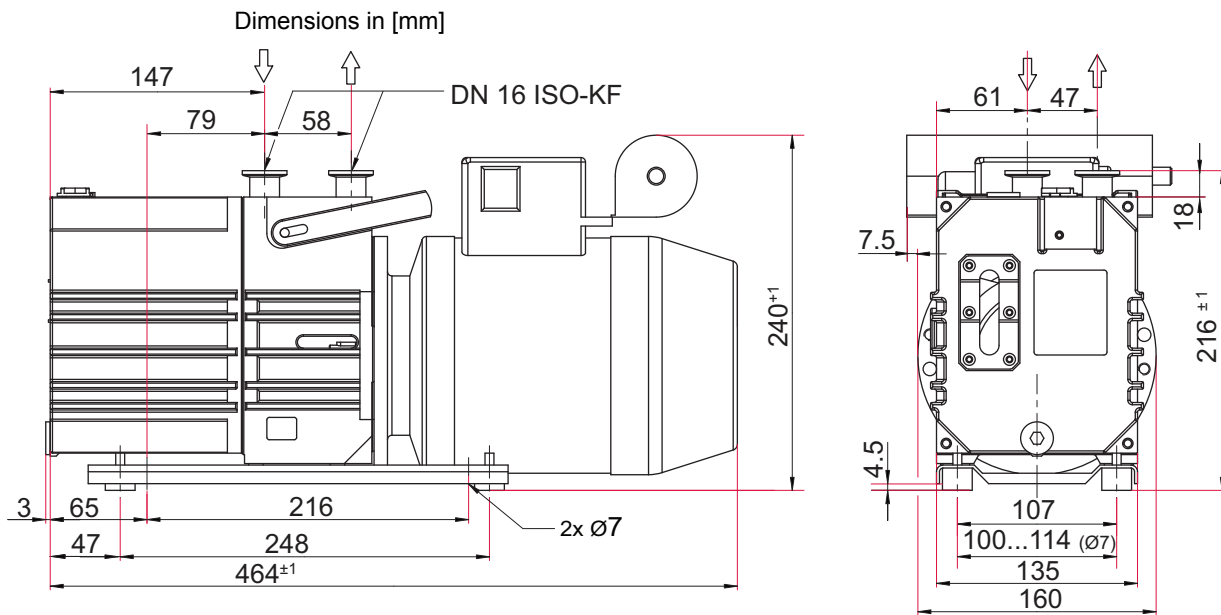

Fig. 22: Dimension diagram Duo 5 M | single-phase motor (115 V)

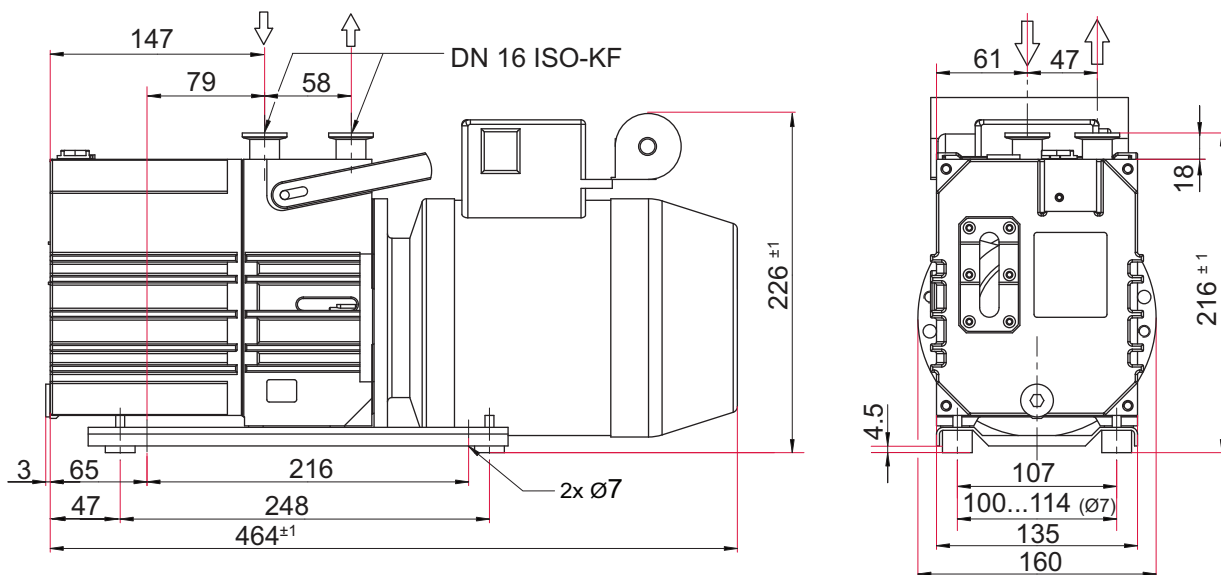

Fig. 23: Dimension diagram Duo 5 M | single-phase motor (230 V)

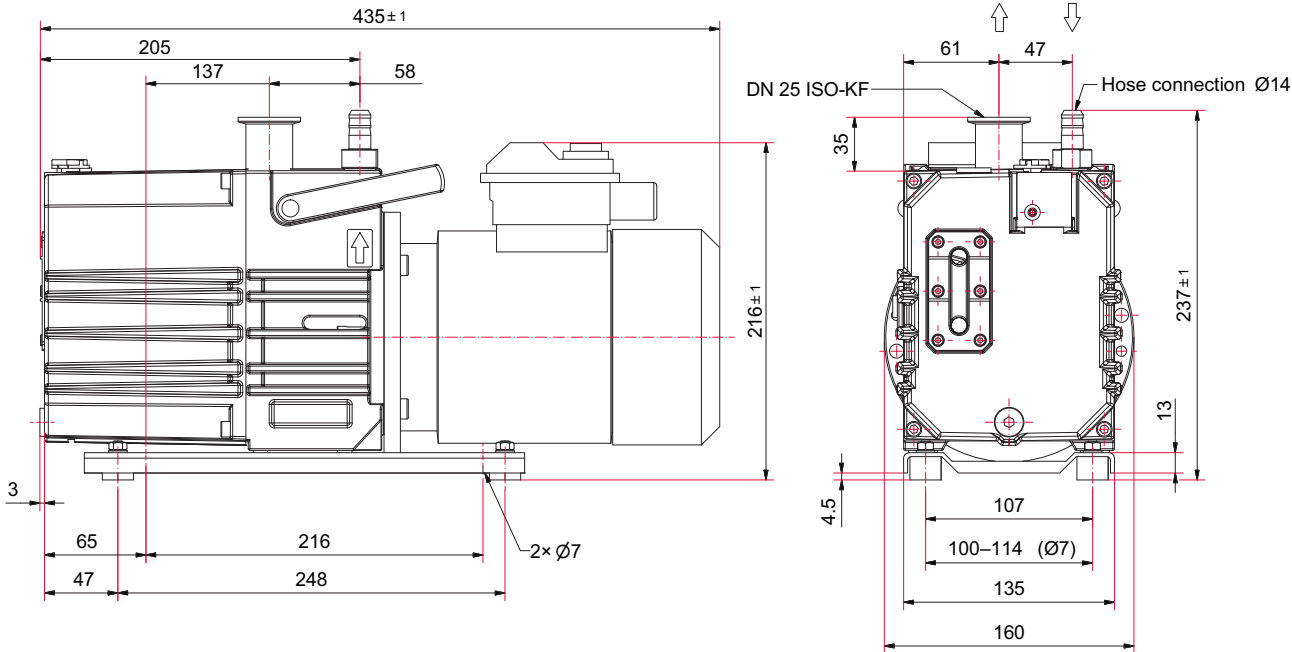

Fig. 24: Dimension diagram Duo 5 M | single-phase motor (230 V, hose connection)

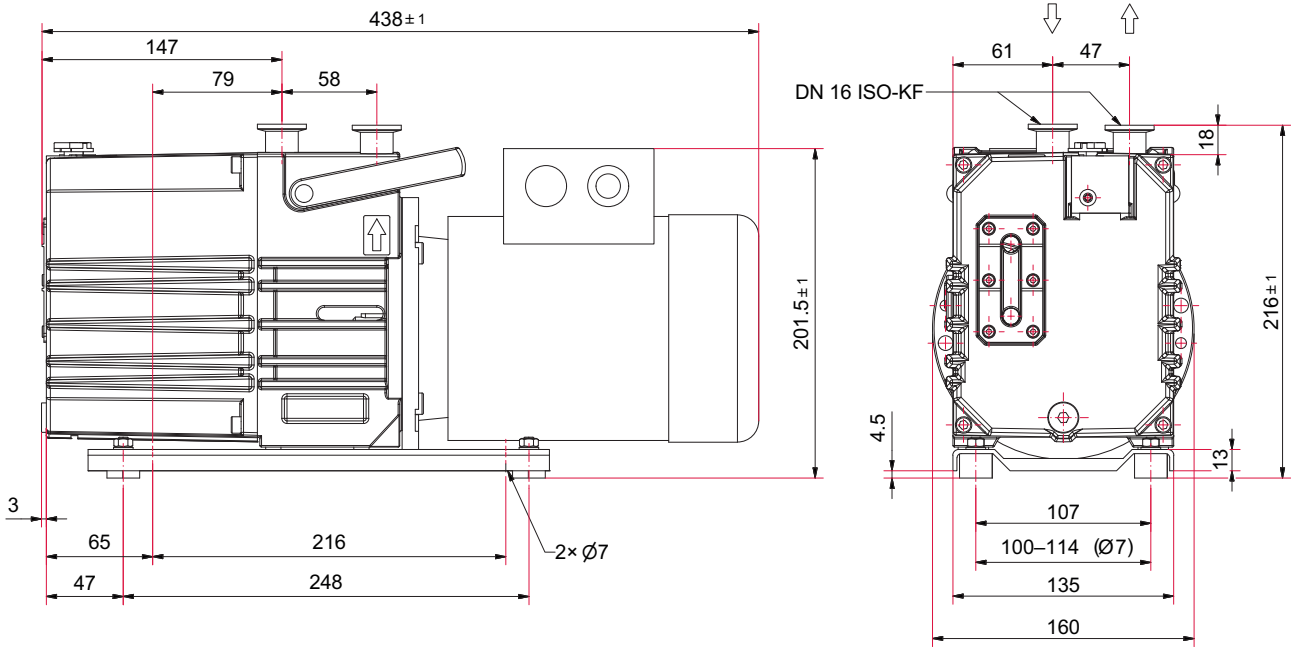

Fig. 25: Dimension diagram Duo 5 M | three-phase motor

EC Declaration of Conformity

Declaration for product(s) of the type:

Rotary vane pump

Duo 5 M

Duo 5 MC

We hereby declare that the listed product satisfies all relevant provisions of the following **European Directives**.

Machinery 2006/42/EC (Annex II, no. 1 A)

Electromagnetic compatibility 2014/30/EU

Restriction of the use of certain hazardous substances 2011/65/EU

Restriction of the use of certain hazardous substances, delegated directive 2015/863/EU

Harmonized standards and applied national standards and specifications:

DIN EN ISO 12100:2011

DIN EN 61010-1:2020

DIN EN 1012-2: 2011

DIN EN IEC 61000-6-2:2019

DIN EN ISO 13857:2020

DIN EN IEC 61000-6-4:2020

DIN ISO 21360-1:2016

DIN EN ISO 2151:2009

ISO 21360-2:2020

DIN EN IEC 63000:2019

The authorized representative for the compilation of technical documents is
Dr. Adrian Wirth, Pfeiffer Vacuum GmbH, Berliner Straße 43, 35614 Asslar, Germany.

Signature:



Pfeiffer Vacuum GmbH
Berliner Straße 43
35614 Asslar
Germany

(Daniel Sälzer)
Managing Director

Asslar, 2019-11-22



UK Declaration of Conformity

This declaration of conformity has been issued under the sole responsibility of the manufacturer.

Declaration for product(s) of the type:

Rotary vane pump

Duo 5 M

Duo 5 MC

We hereby declare that the listed product satisfies all relevant provisions of the following **British Directives**.

Supply of Machinery (Safety) Regulations 2008

Electromagnetic Compatibility Regulations 2016

The Restriction of the Use of Certain Hazardous Substances in Electrical and Electronic Equipment Regulations 2012

Applied standards and specifications:

EN ISO 12100:2010 EN 61010-1:2010 + A1:2019 + A1:2019/AC:2019

EN 1012-2:1996+A1:2009 EN IEC 61000-6-2:2019

EN ISO 13857:2019 EN IEC 61000-6-4:2019

ISO 21360-1:2020 EN ISO 2151:2:2008

ISO 21360-2:2020 EN IEC 63000:2018

The manufacturer's authorized representative in the United Kingdom and the authorized agent for compiling the technical documentation is Pfeiffer Vacuum Ltd, 16 Plover Close, Interchange Park, MK169PS Newport Pagnell.

Signature:



(Daniel Sälzer)
Managing Director

Pfeiffer Vacuum GmbH
Berliner Straße 43
35614 Asslar
Germany

Asslar, 2023-11-30

**UK
CA**

VACUUM SOLUTIONS FROM A SINGLE SOURCE

Pfeiffer Vacuum stands for innovative and custom vacuum solutions worldwide, technological perfection, competent advice and reliable service.

COMPLETE RANGE OF PRODUCTS

From a single component to complex systems:

We are the only supplier of vacuum technology that provides a complete product portfolio.

COMPETENCE IN THEORY AND PRACTICE

Benefit from our know-how and our portfolio of training opportunities!

We support you with your plant layout and provide first-class on-site service worldwide.

ed. R - Date 2311 - P/N:PK0197BEN



Are you looking for a
perfect vacuum solution?
Please contact us

Pfeiffer Vacuum GmbH
Headquarters • Germany
T +49 6441 802-0
info@pfeiffer-vacuum.de

www.pfeiffer-vacuum.com

PFEIFFER  **VACUUM**