



汽车



制冷和空调



包装行业

ASI 35

模块化气体检漏仪
最高性能的氦气和氢气工业检漏系统

ASI 35

模块化气体检漏仪

H₂He

可用氦气及氢气进行
真空法及吸枪法测试



创造更多附加值



循环时间短

完美的解决方案

完美的解决方案ASI 35 是专门为泄漏检测设备制造商和最终用户提供的完美的气体检漏解决方案。该设备提供了高性能、高可靠性和重复性，并且使用寿命非常长。ASI 35 提供了氦气和氢气作为示踪气体检测的优越性能，可用于整体测试和局部测试或两者的结合。当待检样品要求严格，具有最小信号背景和串扰，且样品的总循环时间很短，该设备优越的灵活性可以充分发挥。

灵活多样

由于其模块化设计，ASI 35 经过优化以实现最小空间需求和最大集成选项。该真空模块可以在任何方向上进行安装，所有其他模块可与 1/2 19 英寸机架兼容。由于该设备可通过 PC 或 PLC 进行控制，因此用户界面可选项相应的配置。只需要两根电缆来连接真空模块和电子模块，从而使 ASI 35 成为最容易安装的模块化检漏仪。



适应温度范围广，
可以在各种充满挑
战的环境下运行



吸枪模式具有高气流量



高可靠性



可轻松替换任何其
他模块化检漏仪型号



采用通用电压，
可在全球范围内运行

可靠、快速而灵敏

ASI 35 拥有一个维护率极低的高氮气抽速的高真空泵，使用寿命极长的双独立金属灯丝和最先进的电子设备，从而可以提供持久的无故障运行。该检漏系统可设计用于真空法或吸枪法进行测试的高灵敏度要求的系统中。ASI 35 可以精确保持非常高的气流量，具有高重复性以及循环时间短至 1 秒的快速泄漏检测能力。由于其在吸枪法测试方面无与伦比的性能，ASI 35 成为应用于特定系统的完美检漏仪，尤其是需要多点吸枪法检测的场合。

可在全世界范围内轻松运行

该电子模块配备通用电压，这使得 ASI 35 可以轻松集成到指定的系统中以在世界范围内运行，而检漏仪也适用于环境温度最高达 45 °C 的工作条件。机械集成轻松，而且可进行数据采集的接口范围广泛，还可以对系统进行完全外部控制。由于定制的 I/O 配置，也可以考虑没有 PC 或 PLC 的基础检漏系统。可选的控制面板带有彩色触摸显示屏，通过为设备制造商和最终用户提供的直观设置和软件菜单可轻松操作。

ASI 35

应用领域, 外形尺寸

应用领域

- 汽车：安全气囊充气装置和点火器，冷却散热器，
- 燃油分配管和喷油嘴
- 制冷和空调：蒸发器，压缩机，管道，线圈
- 包装行业：罐和胶囊，软管袋，泡罩
- 机械部件：阀门，配件，阀组



外形尺寸
真空模块

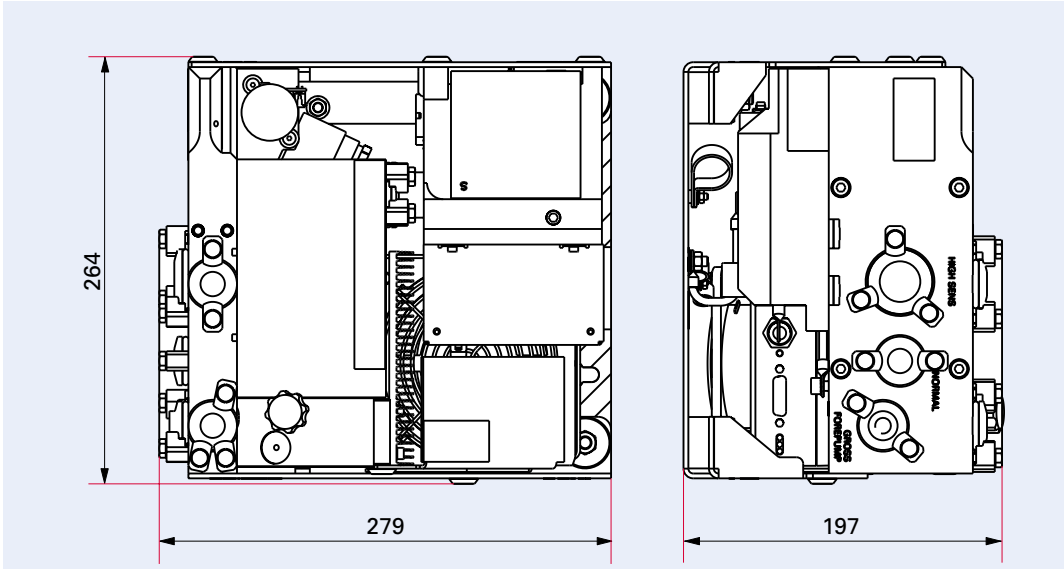

电子模块

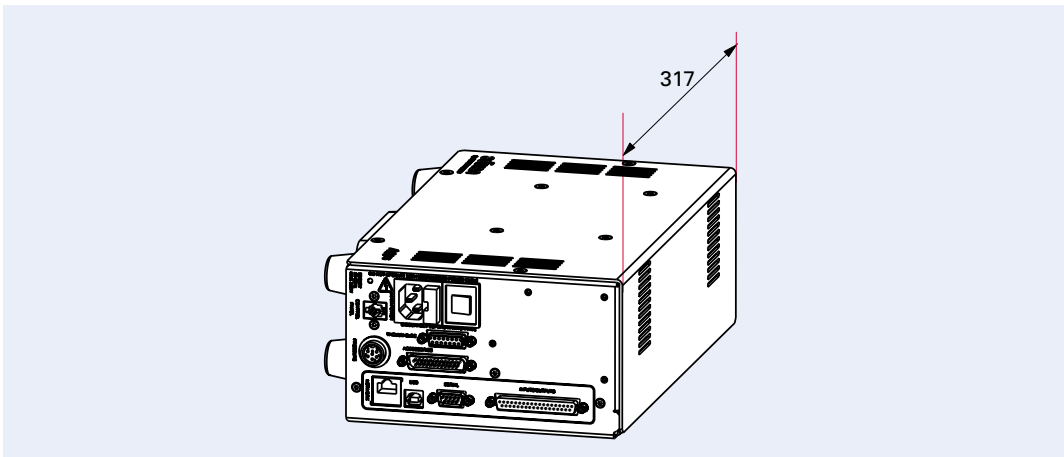

控制面板

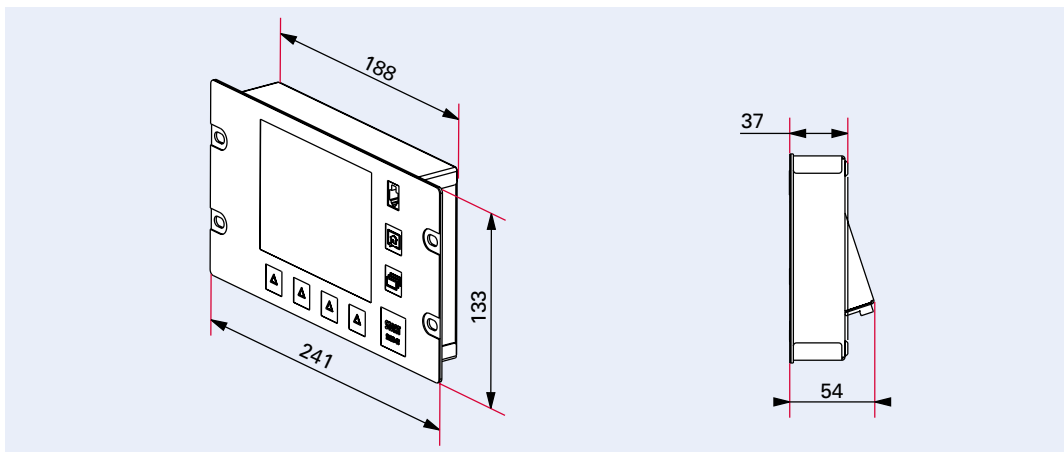

尺寸以mm(毫米)为单位

ASI 35

技术参数, order matrix, 配件

技术参数

	ASI 35
Test methods	Vacuum and sniffing leak detection
Minimum detectable leak rate for He (vacuum leak detection)	3.5 · 10 ⁻⁸ mbar l/s (gross leak test mode) 1 · 10 ⁻¹⁰ mbar l/s (normal leak test mode) 5 · 10 ⁻¹² mbar l/s (high sensitivity test mode)
Minimum detectable leak rate for He (sniffing leak detection)	1,5 · 10 ⁻⁸ mbar l/s
Tracer gases	⁴ He, ³ He, H ₂
Maximum inlet test pressure	18 mbar (gross leak test mode) 1 mbar (normal leak test mode) 0.2 mbar (high sensitivity test mode)
Pumping speed for He	6 l/s (high sensitivity test mode) 1.8 l/s (normal leak test mode)
Start-up time	< 3 min
Vacuum connections	DN 25 ISO-KF; DN 16 ISO-KF
Interface (see the order matrix for complete options configuration)	RS-232, Ethernet, Profibus, USB
I/O interface	6 digital inputs (allocated functions configurable) 3 analog outputs (configurable: helium signal log, mantissa, exponent, inlet pressure) 5 relay outputs (allocated functions configurable) 4 transistor (open collector) outputs (allocated functions configurable)
Dimensions: L × W × H	
Vacuum module:	279 × 264 × 197 mm
Electronic module:	216 × 317 × 111 mm
Control panel:	241 × 54 × 133 mm
Weight	
Vacuum module:	15 kg
Electronic module:	5 kg
Control panel:	1.3 kg
Universal Voltage	90–240 V AC; 50/60 Hz
Maximum power consumption	300 W
Operating temperature	10–45 °C

ASI 35

1,5 · 10⁻⁸ mbar l/s

Minimum detectable
leak rate for He
(sniffing leak detection)

⁴He, ³He, H₂
Tracer gases



Order matrix ASI 35

S a b c 0 d 0 e MM9A

Industrial control panel and associated cable length		a
Without control panel		0
1.8 m		1
5 m		2
10 m		3
Cable length for electronic module		b
1.5 m		1
3.5 m		2
5 m		3
10 m		4
Sniffing		c
Without		X
With		S
Internal calibration		d
Without		0
With		1
Interface board		e
37 Pins E/A		2
37 Pins E/A + Ethernet		4
Profibus		6
Profinet		8

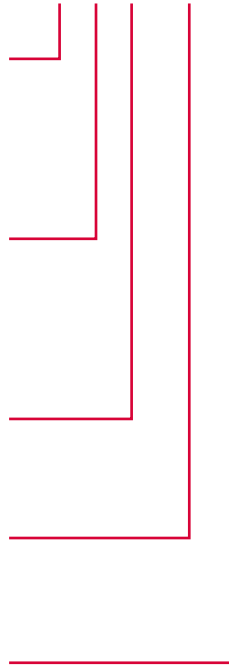

附件订货号

配件	订货号
Sniffing option Sniffing kit	123529
Calibration Calibration kit	123530
Sniffing probe Rigid 9 cm nozzle, 5 m tube length (Other nozzle and tube lengths upon request)	SNC1E1T1
Specific communication interface I/O module type ASI 20 MD	123352

Your Success. Our Passion.

We give our best for you every day –
worldwide!

您是否正在寻找
完美的真空解决方案？
请联系我们：

普发真空技术（上海）有限公司
Pfeiffer Vacuum
(Shanghai) Co., Ltd.
T +86 (21) 3393 3940
info@pfeiffer-vacuum.cn

Pfeiffer Vacuum GmbH
德国总部
T +49 6441 802-0



All information is subject to change without prior notice. PL 0009 PZH (April 2022/0)

Follow us on social media
#pfeiffervacuum



www.pfeiffer-vacuum.cn

PFEIFFER  **VACUUM**